

HEWLETT-PACKARD

Scientific Calculator

Owner's Manual

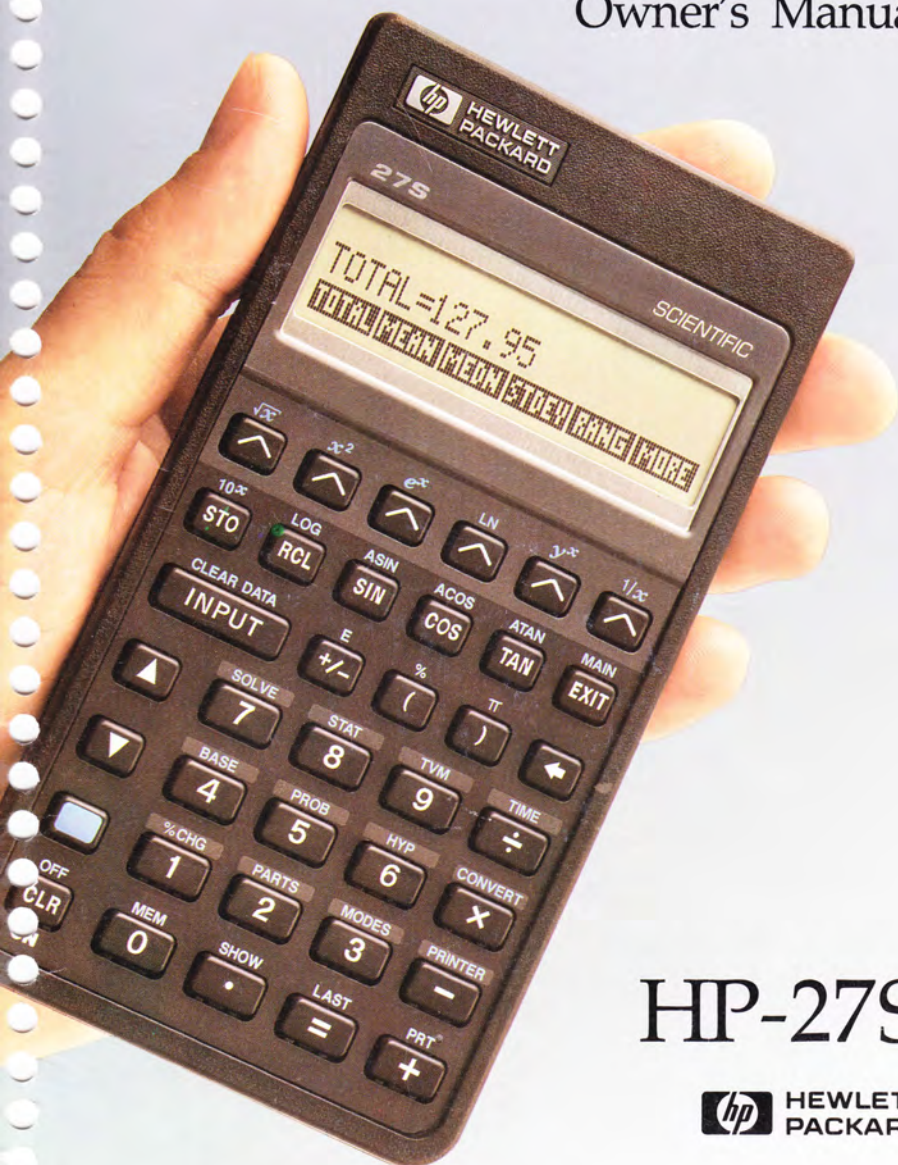

HP-27S

 HEWLETT
PACKARD

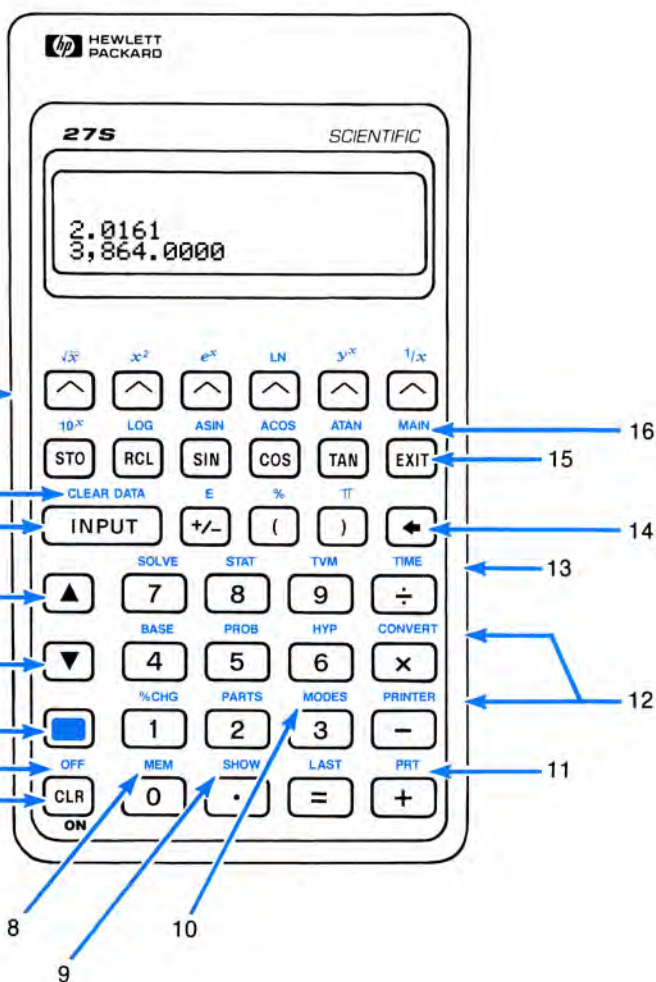

- | | |
|--|-------------------------------|
| 1. Menu keys | 9. Full precision of number |
| 2. Clear portions of memory | 10. Display format; modes |
| 3. Enter data | 11. Print calculator line |
| 4. Move through lists | 12. Numeric and control menus |
| 5. Shift Key | 13. Applications |
| 6. Calculator OFF | 14. Backspace |
| 7. Calculator ON;
clear calculator line | 15. Previous menu |
| 8. Available memory | 16. MAIN display |

HP-27S

Scientific Calculator

Owner's Manual



**HEWLETT
PACKARD**

Edition 2 February 1988
Reorder Number 00027-90028

Notice

For warranty and regulatory information for this calculator, see pages 199 and 203.

This manual and any keystroke programs contained herein are provided "as is" and are subject to change without notice. **Hewlett-Packard Company makes no warranty of any kind with regard to this manual or the keystroke programs contained herein, including, but not limited to, the implied warranties of merchantability and fitness for a particular purpose.** Hewlett-Packard Co. shall not be liable for any errors or for incidental or consequential damages in connection with the furnishing, performance, or use of this manual or the keystroke programs contained herein.

© Hewlett-Packard Co. 1987. All rights reserved. Reproduction, adaptation, or translation of this manual, including any programs, is prohibited without prior written permission of Hewlett-Packard Company, except as allowed under the copyright laws. Hewlett-Packard Company grants you the right to use any program contained in this manual in this Hewlett-Packard calculator.

The programs that control your calculator are copyrighted and all rights are reserved. Reproduction, adaptation, or translation of those programs without prior written permission of Hewlett-Packard Co. is also prohibited.

**Portable Computer Division
1000 N.E. Circle Blvd.
Corvallis, OR 97330, U.S.A.**

Printing History

Edition 1

October 1987

Mfg. No. 00027-90029





Edition 2

February 1988

Mfg. No. 00027-90046

Contents

- 11 List of Examples**
 - 14 How to Use This Manual**
-

- 1 15 Getting Started**
 - 15** Power On and Off
 - 15** The Display
 - 15** The Display Contrast
 - 16** The MAIN Display and Menus
 - 18** The Calculator Line
 - 20** Display Messages
 - 20** Annunciators
 - 21** The Keyboard
 - 21** The  (Shift) Key
 - 21** The  Key
 - 21** Editing and Clearing the Calculator Line
 - 22** Viewing the History Stack With  and 
 - 22** Menu Keys
 - 22** Clearing Portions of Memory With 
 - 22** Using Menus
 - 25** Applications
 - 27** Numeric Function Menus
 - 28** Control Menus
 - 28** Calculations With Variables in Menus
 - 30** Display Mode and Format of Numbers

31	Specifying the Number of Displayed Decimal Places (FIX Mode)
32	Displaying the Full Precision of Numbers
32	Scientific and Engineering Notation
34	Interchanging the Period and Comma
34	Showing the Full Precision of a Number
34	Available Calculator Memory
35	Beeper Function
35	Introducing the Solver and the ALPHA Menu
36	Typing Alphabetic Information
38	Editing Alphabetic Information
40	Solving an Equation

2	42	Keyboard Arithmetic and Numeric Functions
	42	The Calculator Line
	42	Arithmetic Operators
	43	Chain Calculations
	43	Operator Priority
	45	Using Parentheses in Calculations
	46	Reusing the Previous Result ( LAST)
	46	Using Registers
	49	Numeric Functions
	51	General Functions
	53	Logarithmic Functions
	53	Trigonometric and Angle Functions
	59	Probability Functions
	60	Hyperbolic Functions
	61	Parts of Numbers
	62	Range of Numbers

3	63	Base Conversions and Base Arithmetic
	63	Switching Bases
	65	Representation of Numbers
	65	Range of HEX, OCT, and BIN Numbers
	67	Arithmetic Operations

4	69	Statistics
	70	Entering the STAT Application
	71	Entering Data and Calculating the Running Total
	72	Viewing and Editing the List
	74	Copying a List Number to the Calculator Line
	74	Naming and Renaming a List
	75	Switching Lists and Creating New Lists (GET)
	76	Clearing a List
	76	One-Variable Statistics
	79	Statistics Operations With Two Lists
	81	Linear Regression, Curve Fitting, and Estimation
	85	Weighted Mean and Grouped Standard Deviation
	87	Summation Statistics

5	89	The Equation Solver
	90	Entering the SOLVE Application
	91	Entering Equations
	92	Doing Solver Calculations
	93	Clearing Solver Variables
	93	Viewing and Editing the Equation
	94	Naming an Equation
	94	Shared Solver Variables
	95	Deleting the Current Equation and/or Its Variables
	95	Deleting All Equations and/or Their Variables

96	The Syntax of Equations
98	Solver Functions
103	Conditional Expressions (IF Function)
106	Creating Menus for Multiple Equations (S Function)
108	The Summing (Σ) Function
110	Summing Operations With STAT Lists
110	How the Solver Works
110	Direct and Iterative Solutions
111	Halting and Restarting an Iterative Search
112	Entering Guesses
113	Outcomes of an Iterative Solution

6	117	Time Value of Money
	118	Entering the TVM Application
	120	Cash Flow Diagrams and Sign Convention
	122	TVM Calculations
	122	Clearing the TVM Variables
	123	Loan Calculations
	127	Savings Calculations
	130	Amortization
	131	Displaying an Amortization Schedule
	134	Printing an Amortization Schedule

7	136	Time, Appointments, and Date Arithmetic
	136	Viewing the Time and Date
	137	Setting the Time and Date
	139	Changing the Time and Date Formats
	139	Adjusting the Clock Setting
	140	Appointments
	140	Viewing and Setting an Appointment
	142	Acknowledging an Appointment
	143	Unacknowledged Appointments
	143	Clearing Appointments

145	Date Arithmetic
145	Determining the Day of the Week for Any Date
146	Calculating the Number of Days Between Dates
147	Calculating Past or Future Dates
147	Clearing the Date Arithmetic Variables

8	148	Printing
	149	Printing Speed and the Printer's Power Source
	149	Printing the Calculator Line (<input type="checkbox"/> PRT)
	150	Printing Other Information (<input type="checkbox"/> PRINTER)
	150	Printing Variables, Lists, and Appointments
	151	Printing Descriptive Messages
	152	Trace Printing
	153	Interrupting the Printer

9	154	Additional Examples
	154	Vector Calculations
	154	Adding Two Vectors in Polar Coordinates
	156	Angle Between Two Vectors
	158	Projection of One Vector on Another
	160	Laws of Sines and Cosines
	163	Probability Calculations
	165	Simulating a Toss of Dice
	166	Motion of a Projectile
	168	The Catenary Equation
	171	Distance Between Two Locations
	172	Leasing Calculations
	176	Interest Rate Conversions
	179	Finding Several Roots of a Function
	181	Moving Average
	183	Chi-Squared (χ^2) Statistics
	186	Calculating Subtotals
	188	Number of Days Until a Special Day

A	189	Assistance, Batteries, Memory, and Service
	189	Obtaining Help in Operating the Calculator
	189	Answers to Common Questions
	191	Power and Batteries
	191	Low-Power Indications
	192	Installing Batteries
	194	Managing Calculator Memory
	195	Resetting the Calculator
	196	Erasing Continuous Memory
	196	Clock Accuracy
	197	Environmental Limits
	197	Determining If the Calculator Requires Service
	198	Confirming Calculator Operation—The Self-Test
	199	Limited One-Year Warranty
	199	What Is Covered
	200	What Is Not Covered
	200	Consumer Transactions in the United Kingdom
	201	If the Calculator Requires Service
	201	Obtaining Service
	201	Service Charge
	202	Shipping Instructions
	202	Warranty on Service
	202	Service Agreements
	203	Regulatory Information
	203	Radio Frequency Interference
	203	Air Safety Notice (U.S.A.)

B	204	More About The Solver
	204	Direct Solutions
	207	Iterative Solutions
	207	How the Solver Finds a Root Iteratively
	209	The Solver's Ability to Find a Root
	211	Cases Where A Root is Displayed (Cases 1a and 1b)
	215	Case 2 Solutions
	222	Case 3: Bad Guesses
	224	Case 4: When a Solution Isn't Found
	225	Round-off Error

C	226	Equations Used by HP-27S Menus
	226	SOLVE
	228	Statistics
	229	Curve Fitting
	230	TVM
	231	Numeric Function Menus

D	232	Menu Maps and Tables
----------	------------	-----------------------------

	238	Error Messages
--	------------	-----------------------

	243	Index
--	------------	--------------

List of Examples

The following list groups the examples by chapter. The list shows only the examples that require a moderate number of steps.

- 1** **Starting to Use the HP-27S**
- 28** Calculating the Percent Change Between Two Numbers
 - 29** Calculating *NEW* in the %CHG Menu
 - 30** Using the %CHG Menu in a Chain Calculation
 - 36** Writing a Solver Equation for Radioactive Decay
 - 37** Typing the Radioactive Decay Equation
 - 39** Editing the Radioactive Decay Equation
 - 40** Carbon-14 Dating
-

- 3** **Base Conversions and Base Arithmetic**
- 64** Converting Between Bases
 - 67** Arithmetic in HEX, OCT, and BIN Bases
-

- 4** **Statistics**
- 73** Updating a Checkbook
 - 77** One-Variable Statistics Calculations
 - 83** Curve Fitting and Estimation Calculations
 - 85** Weighted Mean and Standard Deviation of Grouped Data
 - 87** Summation Statistics

5	The Equation Solver
89	The Equation of Motion for Free-Fall
94	Temperature Conversions Using Shared Variables
105	Nested IF Functions
107	Unit Conversions
109	A Series Expansion
113	Entering Guesses

6	Time Value of Money
123	A Car Loan
124	A Home Mortgage
125	A Mortgage With a Balloon Payment
127	A Savings Account
129	An Individual Retirement Account
132	Displaying an Amortization Schedule
134	Printing an Amortization Schedule

7	Time, Appointments, and Date Arithmetic
139	Setting the Date and Time
144	Setting and Clearing an Appointment
146	Calculating the Number of Days Between Two Dates
147	Determining a Future Date

8	Printing
152	Trace Printing an Arithmetic Calculation

9**Additional Examples**

- 154** Adding Two Vectors in Polar Coordinates
- 156** Angle Between Two Vectors
- 158** Projection of One Vector on Another
- 160** Law of Sines
- 162** Law of Cosines
- 163** Probability Calculations
- 165** Simulating a Toss of Dice
- 166** Motion of a Projectile
- 168** The Catenary Equation
- 171** Distance Between Two Locations
- 172** Calculating a Lease Payment
- 174** Present (Capitalized) Value of a Lease With Advanced Payments and Option to Buy
- 176** Interest Rate Conversions
- 179** Finding Several Roots of a Function
- 181** Moving Average
- 183** Chi-Squared (χ^2) Statistics
- 186** Calculating Subtotals
- 188** Number of Days Until a Special Day

B**More About the Solver**

- 212** A Case 1 Solution With One Root
- 212** A Case 1 Solution With Two Roots
- 214** A Discontinuous Function
- 216** A Case 2a Solution
- 218** A Case 2b Solution
- 220** A Case 2c Solution (Relative Minimum)
- 221** A Function Dipping to the X-Axis
- 222** A Case 3 Situation

How to Use This Manual

The HP-27S is designed to minimize your need to use the manual. If you enjoy reading manuals cover-to-cover, we hope that you will enjoy immersing yourself in this one. However, we know that most people don't want to put aside whatever they've been doing to savor each paragraph. So, we've written the manual to help you learn about the calculator while you use it.

We have some suggestions for using the manual effectively:

- Read chapter 1 for an overview of how the HP-27S works. It introduces terms and concepts used throughout the manual.
- The HP-27S does keyboard arithmetic using *algebraic* logic. If you are unfamiliar with this way of doing arithmetic calculations, please read pages 43 through 45 in chapter 2 before you do multi-step calculations.
- There are several ways to locate information: the table of contents, the subject index, the list of examples, and the menu maps in appendix D.
- Before doing time-value-of-money problems, learn how the calculator uses positive and negative numbers in financial calculations. For this information, refer to page 120.
- Browse through the examples in chapter 9. You may see a key-stroke example you can use. Just as important, you may find some ideas for putting the HP-27S to work for you.

1

Getting Started

Power On and Off

The HP-27S is powered by three mercury batteries. The calculator is shipped with batteries installed.

To turn on the calculator, press $\boxed{\text{CLR}}$. To turn the calculator off, press the \blacksquare (shift) key, then $\boxed{\text{CLR}}$. Since the calculator has *Continuous Memory*, turning it off does not affect the information you've stored. To conserve energy, the calculator turns itself off 10 minutes after you stop using it.

If you see the low-battery annunciator ($\boxed{\text{---}}$) at the top of the display, you should replace the batteries as soon as possible, using the instructions on page 192.

The Display

The Display Contrast

To adjust the display contrast, hold down $\boxed{\text{CLR}}$ while you press $\boxed{+}$ or $\boxed{-}$.

The MAIN Display and Menu

The display has two major configurations. The “MAIN” display uses both lines to display numbers. Calculations are done on the bottom line, called the *calculator line*, and the result of the previous calculation is shown on the top line.

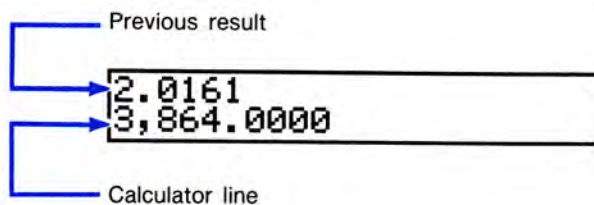

The next illustration shows the configuration of the display after you press **CONVERT** (the **CONVERT** key followed by the **ENTER** key). The calculator line is now the top line, and the bottom line displays the *CONVERT menu*. The menu consists of labels that describe the current function of the *menu keys* at the top of the keyboard.

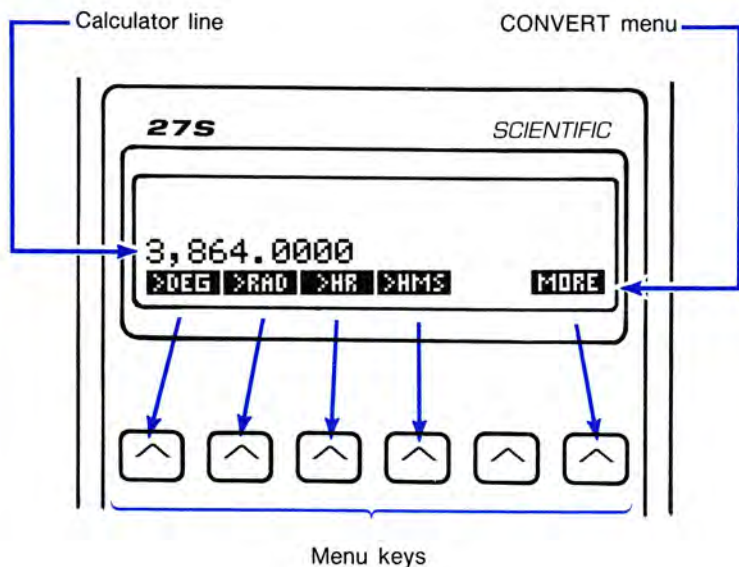

Pressing \blacksquare followed by one of the keys shaded in figure 1-1 displays a menu. Pressing \blacksquare **MAIN** (\blacksquare followed by **EXIT**) always restores the MAIN display. (Sometimes, **EXIT** without \blacksquare restores the MAIN display. “Using Menus” on page 22 explains these keys.)

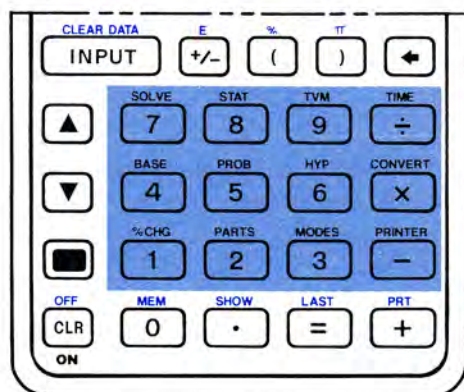
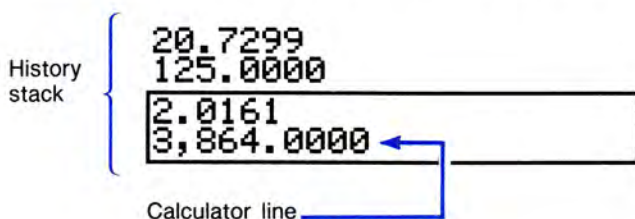

Figure 1-1. Keys That Display Menus

If necessary, press \blacksquare **MAIN** to erase the menu labels. Then, key in these calculations to see how the HP-27S displays the results of previous calculations:

$$\begin{aligned}
 &28.6711 \square - \square 7.9412 \square = \\
 &100 \square + \square 25 \square = \\
 &25 \square \div \square 12.4 \square = \\
 &69 \square \times \square 56 \square =
 \end{aligned}$$

The calculator retains four lines of information—the calculator line and the three previous results. These four lines are the *history stack*.



The Calculator Line

The following examples use the calculator line for simple calculations. Arithmetic calculations are covered in greater detail in chapter 2.

Keys:	Display:	Description:
24.715 $\boxed{+}$	24.715+	
62.471 $\boxed{=}$	87.1860	Adds 24.715 and 62.471.

When a calculation has been completed (by pressing $\boxed{=}$), pressing a number key starts a new calculation.

19 $\boxed{\times}$ 12.68 $\boxed{=}$	240.9200	Calculates 19×12.68 .
---------------------------------------	----------	--------------------------------

If you press an operator key after completing a calculation, the previous result remains in the calculator line.

$\boxed{+}$ 115.5	240.9200+115.5	
$\boxed{=}$	356.4200	Completes the calculation.

Math functions involving one number use the number furthest to the right.

3.57 $\boxed{+}$ 2.36		Calculates 2.36^2 .
$\boxed{x^2}$	3.5700+5.5696	
$\boxed{=}$	9.1396	Completes the calculation.

You can do "chain" calculations without using $\boxed{=}$ after each step.

6.9 $\boxed{\times}$ 5.35 $\boxed{\div}$	36.9150÷	Pressing $\boxed{\div}$ displays the intermediate answer.
.918 $\boxed{=}$	40.2124	

Chain calculations are interpreted according to the priority of the operators (see page 43 for more information).

4 $\boxed{+}$ 9 $\boxed{\times}$ 4.0000+9.0000 \times Addition is delayed; multiplication has higher priority.

3 $\boxed{=}$ 31.0000 Calculates $4 + (9 \times 3)$.

$\boxed{y^x}$ displays the exponentiation operator, \wedge :

4.7 $\boxed{y^x}$ 3 4.7000 \wedge 3 $\boxed{y^x}$ displays \wedge .

$\boxed{=}$ 103.8230 Completes the calculation.

Negative Numbers. There are two ways to key in a negative number:

- Key in the number and press $\boxed{+/-}$.
- If the number follows an operator, you can press $\boxed{-}$ before keying in the number.

Keys:	Display:	Description:
75 $\boxed{+/-}$	-75	Changes the sign of 75.
$\boxed{\div}$ 3 $\boxed{=}$	-25.0000	Calculates $-75 \div 3$.
4.52 $\boxed{\times}$ $\boxed{-}$ 7.1		$\boxed{-}$ after $\boxed{\times}$ changes the sign of 7.1.
$\boxed{\div}$ 12 $\boxed{=}$	-2.6743	

Exceeding the Display Width. When the calculator line contains 22 characters, information scrolls off the left side of the display and three dots appear. Although you can no longer view that numerical information, it is retained in memory.

3,864.0000
 ...3598 \times (1.0000-8.5614 \times

Calculator line contains more than 21 characters

Display Messages

Display messages have three purposes:





- *Help messages* are hints about the keystrokes the calculator expects next or reminders about an assumption the HP-27S is making.
- *Error messages* are displayed and the HP-27S beeps when you attempt incorrect operations. The error messages are listed starting on page 240.
- *Diagnostic messages* are displayed in the SOLVE application at the end of certain complex calculations. These messages are covered in chapter 5.

Messages do not affect the history stack. The messages are cleared when you continue what you were doing by pressing an appropriate key. To clear error messages without doing anything else, press **CLR** or **↓**.

Annunciators





The display has five annunciators to indicate the current status of the calculator.



Table 1-1. Annunciators

Annunciator	Meaning
	Shift (■) is active (page 21).
	The HP-27S is transmitting information to the printer (page 148).
	An appointment is past due (page 143).
	Low batteries (page 191).
RAD	The HP-27S is in radians mode (page 54).





The Keyboard

The (Shift) Key



Most keys have a second function printed in blue above the key. The blue shift key accesses these operations. To do a “shifted” operation, press and release  to turn on the shift annunciator (). Then, press the key. For example, pressing  followed by  (also written ) turns the calculator off.



If you accidentally press , press  again to turn off the shift annunciator.

The Key



The  key is used in certain applications to enter information into memory. You can also use  in place of  in arithmetic calculations. Using  is covered where it is used throughout the manual.



Editing and Clearing the Calculator Line

When the cursor is visible,  (backspace) deletes the last character you keyed in. When the cursor is not visible,  deletes the number furthest to the right.

Pressing  when the calculator is on usually clears the calculator line. When an error message is displayed,  erases the message and restores the original contents of the calculator line.

Viewing the History Stack With and

 and  roll the history stack up and down. You cannot roll the history stack when there is an incomplete calculation in the calculator line.



In the STAT and SOLVE applications,  and  let you view additional stored information.

Menu Keys

The six keys at the top of the keyboard are *menu keys*. The menu keys increase the number of operations available from the keyboard because they change function as you switch menus.

The menu keys have shifted functions— \sqrt{x} , x^2 , etc, that do not change as you switch menus. When menu labels are absent, you can use these functions without pressing .

Clearing Portions of Memory With CLEAR DATA

 CLEAR DATA clears the history stack—the calculator line and the three previous results. In certain menus,  CLEAR DATA also clears data associated with that menu. Using  CLEAR DATA to clear data associated with menus is covered throughout the manual in the discussions of those menus.

Using Menus

Pressing one of the shifted keys labeled with bold letters displays a menu. For example, pressing  %CHG displays the %CHG (percent change) menu:



Percent change menu

The menu keys are now labeled by the bottom line of the display. Here, `OLD`, `NEW`, and `%CH` are variables used to calculate percent change. Pressing `[MAIN]` (or, in this case, `[EXIT]`) erases the menu and restores the MAIN display.

The keys that display menus are described in table 1-2 on page 24. The table is divided according to the three types of menus:

- **Applications.** Each of the four applications consists of a group of menus. Pressing an application key displays the top-level menu in that application. Menus “branching” from the top-level menu allow you to access all the functionality in the application. For example, pressing `[TIME]` displays the TIME menu—the top-level menu in the TIME application. Each key in the TIME menu displays another menu.
- **Numeric functions.** Numeric function menus extend the number of numeric functions available from the keyboard. For example, `[%CHG]` displays the numeric function menu for percent change calculations.
- **Control menus.** Control menus allow you to set certain modes and to control the optional printer.

Some menus contain more than six labels. In those menus, a `MORE` key switches between the “pages” of the menu.

Table 1-2. Menus

Key	Operations Done in This Category	See Chapter:
Applications		
■ SOLVE	Entering equations and solving for variables.	5
■ STAT	Statistics, running total, weighted mean, linear regression, curve fitting, estimation.	4
■ TVM	Time value of money (loans, savings, leasing, amortization).	6
■ TIME	Clock, calendar, appointments, date arithmetic.	7
Numeric Function Menus		
■ BASE	Number base conversions (decimal, hexadecimal, octal, binary).	3
■ PROB	Probability (permutations, combinations, factorial, random number)	2
■ HYP	Hyperbolic and inverse hyperbolic functions.	2
■ CONVERT	Convert between: <ul style="list-style-type: none"> ■ Degrees and radians. 2 ■ Hours.Decimal hours and Hours.MinutesSeconds. 2 ■ Polar and rectangular coordinates. 2 	
■ %CHG	Percent change between two numbers.	2
■ PARTS	Number-altering functions (integer part, absolute value, etc.)	2
Control Menus		
■ MODES	Switch calculator modes: <ul style="list-style-type: none"> ■ Display modes: FIX, scientific, engineering; interchanging the period and comma. 1 ■ Angle modes: degrees, radians. 2 ■ Beeper modes. 1 ■ Printer power: battery, AC. 8 	
■ PRINTER	Printing stored information.	8

Applications

Figure 1-2 illustrates two menu levels in the STAT application—the top-level STAT menu (displayed when you press **STAT**) and the CALC menu (displayed when you press **CALC**). The illustration shows the function of several other keys:

- Use **EXIT** to display the previous menu. Exiting from the top level of an application restores the MAIN display.
- Use **MAIN** to leave the application and restore the MAIN display.

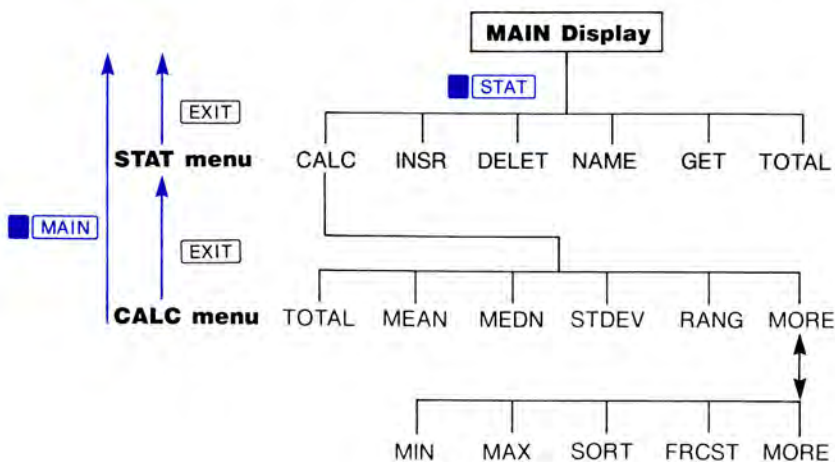

Figure 1-2. An Application Menu Map

Figure 1-3 illustrates switching from one application to another. You do not need to press **MAIN** to switch applications; pressing an application key (for example, **STAT**) performs two operations—an exit from the previous application, and entry into the top-level menu of the new application.

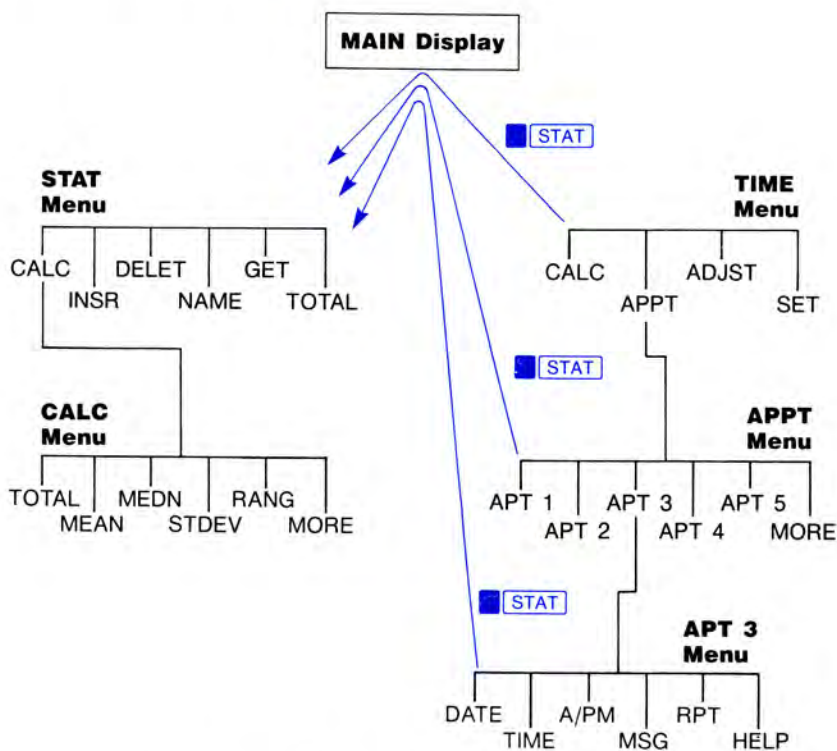

Figure 1-3. Switching Applications

Numeric Function Menus

The major differences between numeric function menus and application menus are:

- Numeric function menus have only one level; there are no menus branching from these menus.
- Numeric functions can be used within applications without leaving the application.

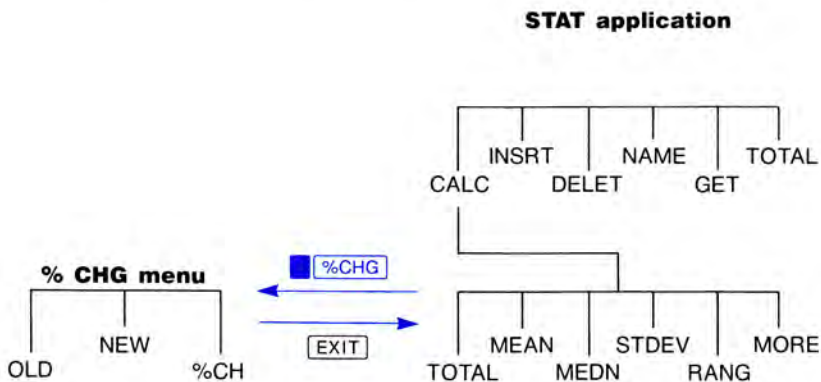

Figure 1-4. Using a Numeric Function Menu in an Application

Numeric function menus replace one another (see figure 1-5). For example, if you display the **%CHG** menu and then switch to the **HYP** menu, **[EXIT]** does *not* return to the **%CHG** menu.

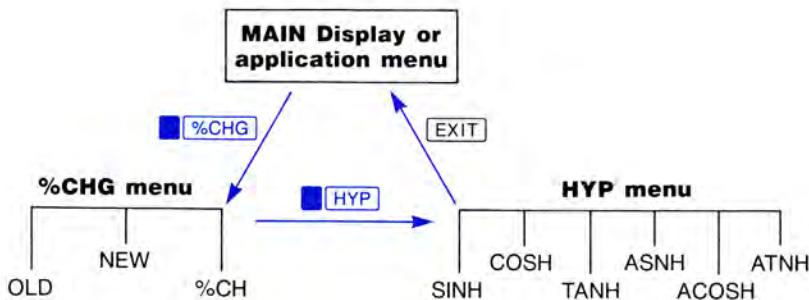

Figure 1-5. Switching Numeric Function Menus

Control Menus

Each control menu has one level. Exiting a control menu always displays the menu you were viewing previously. When the control operation performed is setting the display format or printing stored data, the exit occurs automatically.

Calculations With Variables in Menus

Many application and numeric function menus do calculations using a set of variables accessed by menu keys. The variables are a named location in calculator memory. You use the menu keys to store numbers into the known variables and to solve for the unknown variable.

Example: Calculating the Percent Change Between Two Numbers. Calculate the percent change between 37.5 and 55.6 using the %CHG menu.

Press **■** **%CHG** to display the %CHG menu, which consists of the variables *OLD*, *NEW*, and *%CH*. The following illustration shows the keystrokes for doing the calculation.

Keys: 55.6 **NEW**
Display: NEW=55.6000

Keys: 37.5 **OLD**
Display: OLD=37.5000

Keys: **%CH**
Display: %CHANGE=48.2667

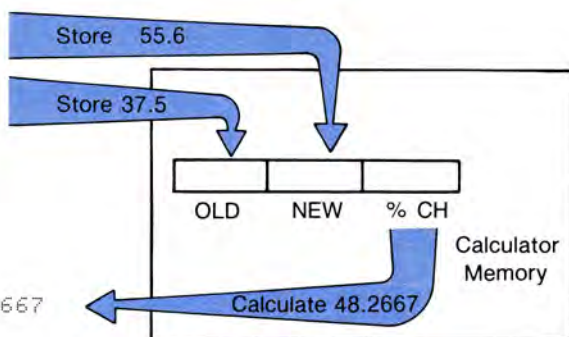

Example: Calculating NEW in the %CHG Menu. Calculate the number 15% less than 25.85. This calculation uses the same three variables:

Keys: 15 **+/-** **%CH**
Display: %CHANGE=-15.0000

Keys: 25.85 **OLD**
Display: OLD=25.8500

Keys: **NEW**
Display: NEW=21.9725

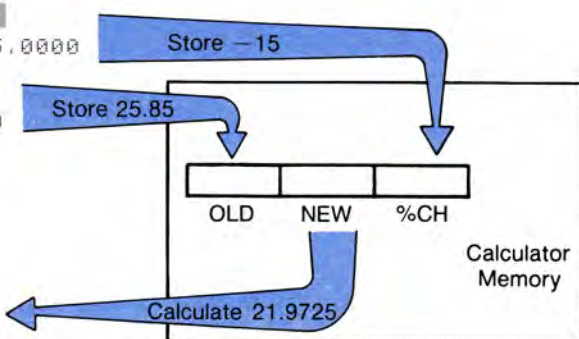

The rules for using menu variables are:

- **To store a value,** key in the number and press the menu key.

If the calculator line contains an expression (for example, 2×50), the expression is evaluated and the result (in this case, 100) is stored. To store only the rightmost number, press **[STO]** before pressing the menu key. Also use **[STO]** to store a number on the calculator line that was previously calculated (one that you haven't just keyed in).

- **To calculate a value**, press a menu key without first keying in a number. In other words, when you press two menu keys one after another, the second key does a calculation. During calculations, the message `CALCULATING...` is briefly displayed.
- **To recall a previously stored or calculated value**, press `[RCL]` followed by the menu key. For example, `[RCL] [OLD]` displays the value in `OLD`.
- **To clear all the variables in a menu**, press `[CLEAR DATA]` while the menu is displayed. The history stack is also cleared.
- **Certain variables are store-only or calculate-only**. The menu maps in appendix D indicate these variables.

Example: Using the %CHG Menu in a Chain Calculation. Add the percent change between 16 and 25 to the product of $45 \times .95$. `[STO]` is used to store only the rightmost number on the calculator line.

Keys:	Display:	Description:
<code>45 [x] .95 [+]</code>	<code>42.7500+</code>	Calculates the product.
<code>[%CHG] 16</code>		Stores 16 in <code>OLD</code> .
<code>[STO] [OLD]</code>	<code>42.7500+16.0000</code>	
<code>25 [STO]</code>		Stores 25 in <code>NEW</code> .
<code>[NEW]</code>	<code>42.7500+25.0000</code>	
<code>[%CH]</code>	<code>42.7500+56.2500</code>	Calculates <code>%CH</code> .
<code>[=]</code>	<code>99.0000</code>	Completes the calculation.

Display Mode and Format of Numbers

When you turn on the HP-27S for the first time, numbers are displayed with four decimal places and a period as the decimal point. The *display mode* controls how numbers are formatted in the display. The `MODES` menu is used to change the display mode.

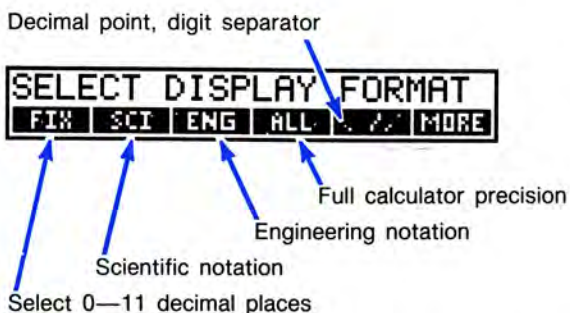

Regardless of the display mode, each number is stored as a signed, 12-digit mantissa with a signed, three-digit exponent.* For example, pressing π in FIX 4 mode displays 3.1416. Internally, the number is stored as $3.14159265359 \times 10^{000}$.

Specifying the Number of Displayed Decimal Places (FIX Mode)

To specify the number of displayed decimal places:

1. Press MODES .
2. Press FIX . Key in the number of decimal places (an integer from 0 to 11) and press INPUT .

* During complex internal calculations, the HP-27S uses 15-digit precision for intermediate results.

Keys:	Display:	Description:
45.6 \times .1256 =	5.7274	Initially, 4 decimal places.
MODES FIX 3 INPUT	5.727	Displays 3 decimal places.
MODES FIX 6 INPUT	5.727360	Displays 6 decimal places.
MODES FIX 4 INPUT	5.7274	Restores four decimal places.

When a number is too large or too small to be displayed in FIX format, it is displayed in scientific notation.

Displaying the Full Precision of Numbers

To display numbers as precisely as possible up to a maximum of 12 digits, press **MODES** **ALL**.

Scientific and Engineering Notation

Scientific Notation. Scientific notation expresses a number as a mantissa with one digit to the left of the decimal point, multiplied by 10 raised to a power.

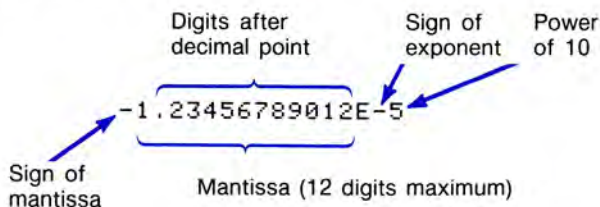

To specify scientific notation:

1. Press **MODES**, then **SCI**.
2. Key in the number of decimal places in the mantissa (0 through 11) and press **INPUT**.

Engineering Notation. Engineering notation expresses a number as a mantissa with one, two, or three digits to the left of the decimal point, multiplied by 10 raised to a power divisible evenly by 3.

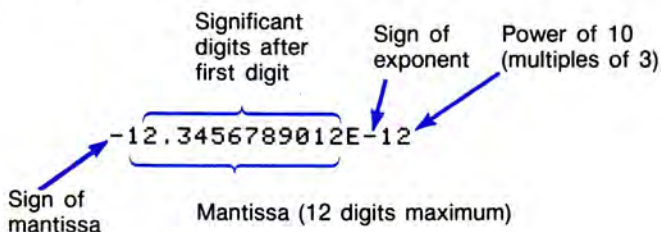

To specify engineering notation:

1. Press **MODES**, then **ENG**.
2. Key in the number of significant digits to be displayed after the first digit and press **INPUT**.

Keying in Numbers With Exponents. Regardless of the current display mode, you can always key in a number as a mantissa followed by an exponent:

1. Key in the mantissa. If the mantissa is negative, use **+/-** to change the sign.
2. Press **E** to start the exponent.
3. If the exponent is negative, press **-**.
4. Key in the exponent.

Keys:

4.78 **[E]** 13
[÷] 8 **[E]** 25
[=]

Display:

5.9750E-13

Description:

$4.78 \times 10^{13} \div 8 \times 10^{25}$
 equals 5.9750×10^{-13} .

2.36 **[+/-]** **[E]**
[−] 15 **[×]** 12 **[=]**

-2.8320E-14

$-2.36 \times 10^{-15} \times 12 =$
 -2.832×10^{-14} .

Interchanging the Period and Comma

You can interchange the characters used as the decimal point and digit separator. For example, one million can be displayed:

1,000,000.0000 or 1.000.000,0000

To interchange the decimal point and digit separator, press **[MODES]**, then **[.,/]**.

Showing the Full Precision of a Number

To temporarily view the full 12-digit precision of the number in the calculator line, press **[F]** and then hold down **[SHOW]**. If there are more than two numbers in the calculator line, only the rightmost number is shown. Release **[SHOW]** to restore the calculator line.

Available Calculator Memory

The HP-27S has approximately 6,900 bytes of memory available for your use. **[MEM]** displays the amount of unused memory. The information is displayed until you release **[MEM]**.

AVAILABLE MEMORY: 6,005 BYTES	86%
----------------------------------	-----

If you attempt an operation that requires more memory than you currently have available, the HP-27S displays:

INSUFFICIENT MEMORY

You must erase a portion of your previously stored information before proceeding (see “Managing Calculator Memory” on page 194 for additional information). You can also erase *all* the information you’ve stored (see “Erasing Continuous Memory” on page 196).

Beeper Function

Ordinarily, the beeper is on, and the calculator sounds an audible tone when error messages are displayed and when appointments come due. However, the HP-27S has three beeper modes for controlling when the beeper sounds. To change the beeper mode:

1. Press **MODES** **MORE**.
2. Press **BEEP** one or more times to change the mode, until the HP-27S displays the appropriate message:
 - **BEEPER ON: APPTS ONLY.** The beeper sounds only when an appointment comes due.
 - **BEEPER OFF.** The beeper does not sound.
 - **BEEPER ON.** The beeper sounds when an appointment comes due and when error messages are displayed.
3. Press **EXIT**.

Introducing the Solver and the ALPHA Menu

The SOLVE application, or Solver, lets you enter your own equations and create menus consisting of the variables in those equations. This is a brief introduction to the Solver. Because equations usually contain alphabetic characters, this section also explains how to type letters and other characters not present on the keyboard. The Solver is covered in detail in chapter 5.

Example: Writing a Solver Equation for Radioactive Decay. The equation for computing the rate of decay of radioactive substances is:

$$-kt = \ln \frac{N}{N_0}$$

where:

t = elapsed time.

k = the rate constant for the decay, characteristic of the particular substance. Variables t and k must use the same time units.

N_0 = the amount of the substance present at $t = 0$.

N = the amount of the substance present at time t .

The equation must be written in a form the Solver can interpret:

Optional spaces

$$-K \times T = \underbrace{\text{LN}(N \div N_0)}$$

Solver function

Typing Alphabetic Information

The ALPHA menu is displayed when you press **NEW** in the SOLVE menu, and at other times when you need to enter alphabetic characters. It allows you to type the characters that are not on the keyboard:

- Uppercase letters A through Z.
- Space.
- Various other characters, including punctuation and non-English letters.

The letters A through Z are displayed by pressing two menu keys; for example, **A** is displayed by pressing **ABCDE** **A**. Pressing **A** restores the ALPHA menu, so you are ready to type the next character.

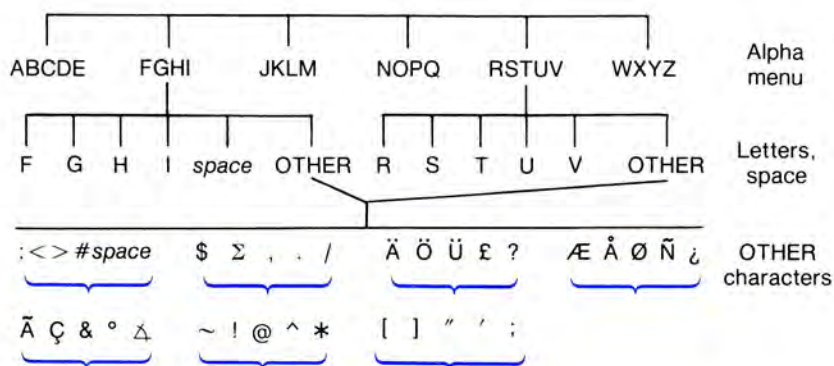

Each letter menu has an **OTHER** key for accessing characters other than A through Z. Pressing **OTHER** in any letter menu displays the same set of five characters plus **MORE**, which allows you to page through seven sets of characters.

The letter menus with only four letters (for example, N through Q) include a space character ().

The following keystrokes enter the radioactive decay equation. You can use $\left[\blacktriangleleft \right]$ to correct typing mistakes discovered right away. To do further editing, refer to the next section, "Editing Alphabetic Information."

Example: Typing the Radioactive Decay Equation. Use these keystrokes to enter the equation $-K \times T = LN(N \div N0)$ into the Solver:

Keys:

- $\left[\text{SOLVE} \right]$ $\left[\text{NEW} \right]$
- $\left[- \right]$
- $\left[\text{JKLM} \right]$ $\left[\text{K} \right]$
- $\left[\times \right]$
- $\left[\text{RSTUV} \right]$ $\left[\text{T} \right]$
- $\left[\text{WXYZ} \right]$ $\left[\text{space} \right]$
- $\left[= \right]$

Display:

- ALPHA menu
-
- K
- K×
- K×T
- K×T (space)
- K×T =

ABCDE OTHER (another way to display a space)

LN (typing aid) or

JKLM L NOPQ N ()

NOPQ N

+

NOPQ N

0 ("zero" key)

)

INPUT

-K×T = (space)

-K×T = LN<

-K×T = LN<N

-K×T = LN<N÷

-K×T = LN<N÷N

-K×T = LN<N÷N0

-K×T = LN<N÷N0)

Enters the equation into memory.

LN is a typing aid during alphabetic entry. (Table 5-3 on page 98 lists the other typing aids.) The application keys (SOLVE, STAT, etc.) are not active when the ALPHA menu is displayed.

Editing Alphabetic Information

The ALPHA menu has a companion menu, the ALPHA-edit menu, which is displayed when you exit from the ALPHA menu or when you press EDIT in the SOLVE menu.*

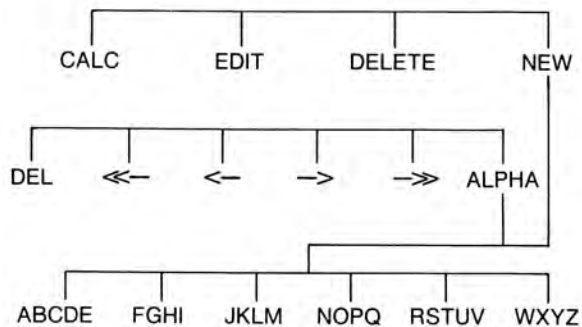

* The ALPHA-edit menu is "skipped over" when it makes no sense to display it—for example, when you press NEW in the SOLVE menu, and when you press EXIT in the ALPHA menu before typing any characters.

Table 1-2 describes the keys for editing alphabetic information. No insert key is necessary—characters are inserted at the cursor position.

Table 1-2. Alphabetic Editing Keys

Key	Description
ALPHA-Edit Menu	
DEL	Deletes the character at the cursor position.
<<--	Moves the cursor to the left side of the display; when pressed again, moves the cursor one display width to the left.
<--	Moves the cursor one position to the left.
-->	Moves the cursor one position to the right.
-->>	Moves the cursor to the right side of the display; when pressed again, moves the cursor one display width to the right.
ALPHA	Displays the ALPHA menu.
Keyboard Keys	
	Backspace; erases the character to the left of the cursor.
CLR	Clears the calculator line.

Example: Editing the Radioactive Decay Equation. Name the radioactive decay equation entered on pages 37 and 38 DECA~~Y~~. (Names are used to identify equations. They precede the equation and are separated from it by a colon.) Also delete the spaces before and after the equal sign.

Keys:

EDIT	ALPHA
ABCDE	D
ABCDE	E
ABCDE	C

Display:

-K×T = LN(N÷N0)
 D-K×T = LN(N÷N0)
 DE-K×T = LN(N÷N0)
 DEC-K×T = LN(N÷N0)

ABCDE A
 WXYZ Y
 ABCDE OTHER :
 EXIT -> (four times) DEL
 -> DEL
 INPUT

DECA- $K \times T = \text{LN}(N \div N0)$
 DECAY- $K \times T = \text{LN}(N \div N0)$
 DECAY:- $K \times T = \text{LN}(N \div N0)$
 DECAY:- $K \times T = \text{LN}(N \div N0)$
 DECAY:- $K \times T = \text{LN}(N \div N0)$
 Enters the edited equation.

Solving an Equation

Press **CALC** to display the menu of variables for the radioactive decay equation entered on pages 37 and 38.

0.0000			
K	T	N	N0

Example: Carbon-14 Dating. Wood on the outer surface of a giant sequoia tree exchanges carbon with its environment. The radioactivity of this wood is 15.3 counts per minute per gram of carbon. A sample of wood from the center of the tree yields 10.9 counts per minute per gram of carbon. The rate constant for the radioactive form of carbon, ^{14}C , is 1.20×10^{-4} . How old is the tree? What is the half-life of ^{14}C ?

Keys:

Display:

Description:

1.2 **E** **-** 4
K

$K = .0001$

Stores rate constant.

10.9 **N**

$N = 10.9000$

Stores activity at time T .

15.3 **N0**

$N0 = 15.3000$

Stores initial activity.

T

$T = 2,825.7503$

Calculates age of the tree in years.

Calculate the half-life ($t_{1/2}$) of ^{14}C , that is, the time required for half the material present to decay.

1 **N**

$N=1.0000$

$N=1$ is derived from the ratio $N/N_0 = 1/2$ when $t = t_{1/2}$.

2 **N0**

$N0=2.0000$

Stores N_0 .

T

$T=5,776.2265$

Calculates half-life.

EXIT

Displays the SOLVE menu.

Keyboard Arithmetic and Numeric Functions

The Calculator Line

The calculator line is almost always present. It occupies the bottom line of the MAIN display, and moves to the top line of the display when menu labels are present.

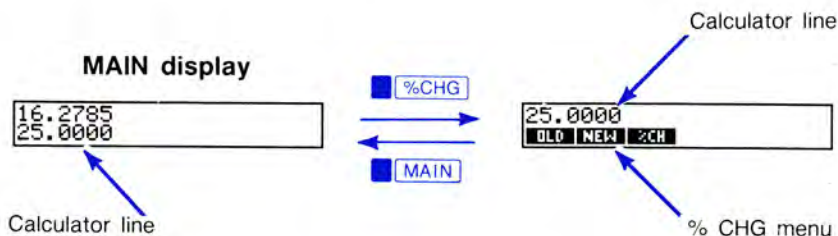

The calculator line can contain messages and labeled numbers, such as MEAN=124.60. Pressing an operator or numeric function key erases the label and continues the calculation. For example, pressing $\boxed{+}$ $\boxed{2}$ $\boxed{=}$ would calculate 124.60 plus 2.

Arithmetic Operators

The following keystrokes illustrate simple arithmetic operations.

Keys:	Display:	Description:
54.69 $\boxed{+}$ 28.33 $\boxed{=}$	83.0200	Addition.
750 $\boxed{\times}$ 12 $\boxed{=}$	9,000.0000	Multiplication; pressing a number key after $\boxed{=}$ starts a new calculation.
$\boxed{\div}$ 360 $\boxed{=}$	25.0000	Division; pressing an operator key after $\boxed{=}$ continues the calculation.
5 $\boxed{y^x}$ 4 $\boxed{=}$	625.0000	Exponentiation.
$\boxed{\text{MAIN}}$ 6 $\boxed{y^x}$ 3 $\boxed{=}$	216.0000	$\boxed{\text{MAIN}}$ before $\boxed{y^x}$ is unnecessary in the MAIN display.

Chain Calculations

Chain calculations do a sequence of operations without pressing $\boxed{=}$ after each operation. Chain calculations evaluate expressions using the system of *operator priority* described in the next section.

Keys:	Display:	Description:
750 $\boxed{\times}$ 12 $\boxed{\div}$	9,000,0000 \div	Calculates intermediate value.
360 $\boxed{=}$	25.0000	Completes the calculation.

Operator Priority

Some chain calculations might be interpreted several different ways. For example, $9 + 12 \div 3$ has two interpretations:

$$9 + \frac{12}{3} = 13 \quad \text{or} \quad \frac{9 + 12}{3} = 7$$

The HP-27S uses a system of operator priority to evaluate expressions:

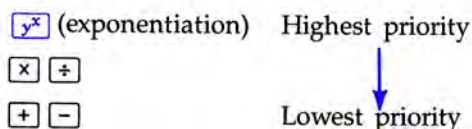

The HP-27S calculates an intermediate result when the next operator you key in has lower or equal priority.

Calculate $9 + \frac{12}{3}$:

Keys:

Display:

Description:

9 $+$ 12 \div

9.0000+12.0000÷

Pressing \div does not add $9 + 12$; \div has higher priority than $+$.

3 $=$

13.0000

Calculate 4×7^3 plus 5×7^2 plus 6.

4 \times 7 y^x

4.0000×7.0000^

y^x has higher priority than \times .

3 $+$

1,372.0000+

Calculates 4×7^3 .

5 \times

1,372.0000+5.0000×

\times has higher priority than $+$.

7 y^x 2

...0000+5.0000×
7.0000^2

y^x has higher priority than \times .

$+$

1,617.0000+

Adds 5×7^2 to 1,372.

6 $=$

1,623.0000

Completes the calculation.

If a calculation requires that operations be done in an order inconsistent with operator priority (for example, addition *before* multiplication), use parentheses.

Using Parentheses in Calculations

Use parentheses to group operations and to specify the order in which they are performed.*

Calculate $\frac{9 + 12}{3}$:

Keys:

([9 + 12])

Display:

21.0000

Description:

[] evaluates contents of parentheses.

÷ 3 =

7.0000

Calculate $\frac{30}{85 - 12} \times \sqrt{16.9 - 8}$:

30 ÷ ([85 -])

30.0000 ÷ (85.0000 -

Parenthesis prevents dividing 30 by 85.

12])

30.0000 ÷ 73.0000

[] evaluates inside of parentheses.

×

0.4110 ×

Calculates $30 \div 73$.

([16.9 - 8])

0.4110 × 8.9000

[] evaluates contents of parentheses.

√

0.4110 × 2.9833

Calculates $\sqrt{8.9}$.

=

1.2260

Completes the calculation.

* Closing parentheses at the end of the expression can be omitted. For example, $25 \div (3 \times (9 + 12) =$ is equivalent to $25 \div (3 \times (9 + 12)) =$.

Reusing the Previous Result (**LAST**)

LAST copies the previous result into a calculation you are in the process of doing. The following keystrokes use **LAST** to calculate:

$$\begin{aligned} &.0821 \times (18 + 273.1) = ? \\ 2 \times .0821 \times (18 + 273.1) &= ? \\ 3 \times .0821 \times (18 + 273.1) &= ? \end{aligned}$$

Keys:	Display:	Description:
.0821 x (18 + 273.1) =	23.8993	First answer.
2 x LAST	2.0000×23.8993	
=	47.7986	Second answer.
CLR	0.0000	Clears calculator line; prevents 47.7986 from becoming last.
3 x LAST		Third answer.
=	71.6979	

Using Registers

The HP-27S has 10 registers for storing numbers— R_0 through R_9 . They are accessed using **STO** and **RCL**.

- **STO** n , where n is an integer 0 through 9, copies the rightmost number in the calculator line to the designated register. The number is copied with full precision.
- **RCL** n copies the contents of R_n to the calculator line. The number is displayed in the current display format.

To cancel store or recall after you've pressed **STO** or **RCL**, press **⏏**.

The following keystrokes use R_1 and R_2 to calculate:

$$\frac{(27.1 + 35.6) \times 1.0823}{(27.1 + 35.6)^{1.0823}}$$

Keys:	Display:	Description:
27.1 $\boxed{+}$ 35.6 $\boxed{=}$	62.7000	
$\boxed{\text{STO}}$	STO _	Calculator awaits register number.
1	62.7000	Stores 62.7 in R_1 .
$\boxed{\times}$ 1.0823 $\boxed{\text{STO}}$ 2	62.7000 \times 1.0823	Stores 1.0823 in R_2 .
$\boxed{\div}$	67.8602 \div	
$\boxed{\text{RCL}}$	RCL _	Calculator awaits register number.
1	67.8602 \div 62.7000	Recalls contents of R_1 .
$\boxed{y^x}$ $\boxed{\text{RCL}}$ 2	...8602 \div 62.7000 \wedge 1.0823	Recalls contents of R_2 .
$\boxed{=}$	0.7699	Exponentiation is done before division.

Clearing Registers. To clear a register, store 0 in it. It is unnecessary to clear a register before storing a value, since $\boxed{\text{STO}}$ n replaces the previous value with the new value. Furthermore, the registers are not accessed by any applications or functions.

Arithmetic in Registers. Table 2-1 describes the arithmetic operations that can be performed on numbers stored in registers.

Table 2-1. Arithmetic in Registers

Keys	New Number in Register
$\boxed{\text{STO}}$ $\boxed{+}$ n	old number + displayed number
$\boxed{\text{STO}}$ $\boxed{-}$ n	old number - displayed number
$\boxed{\text{STO}}$ $\boxed{\times}$ n	old number \times displayed number
$\boxed{\text{STO}}$ $\boxed{\div}$ n	old number \div displayed number
$\boxed{\text{STO}}$ $\boxed{y^x}$ n	old number \wedge displayed number

The following keystrokes use two registers to calculate:

$$1.097 \times 25.6671 = ?$$

$$1.097 \times 35.6671 = ?$$

Keys:	Display:	Description:
1.097 [STO] 0	1.0970	Stores 1.097 in R_0 .
[x] 25.6671 [STO] 1	1.0970×25.6671	Stores 25.6671 in R_1 .
[=]	28.1568	First answer.
[RCL] 0	1.0970	Recalls contents of R_0 and starts a new calculation.
[x] 10 [STO] [+]	STO + _	Calculator awaits register number.
1	1.0970×10.0000	Adds 10 to contents of R_1 .
[RCL] 1	1.0970×35.6671	Contents of R_1 replace rightmost number.
[=]	39.1268	Second answer.

You can also do arithmetic with the values stored in variables. For example, 2 **[STO]** **[x]** **OLD** (in the %CHG menu) multiplies the current contents of *OLD* by 2 and stores the product in *OLD*.

Numeric Functions

Many of the numeric functions are visible on the keyboard—for example, **[SIN]** (sine), **[LOG]** (base 10 logarithm). Others are in *function menus* (see figure 2-1 on page 50).

This section describes each of the numeric functions, categorized as follows:

- General functions: \sqrt{x} , x^2 , $1/x$, %, and %CHG (percent change).
- Logarithmic functions: LN, e^x , LOG, 10^x .
- Trigonometric and angle functions:
 - Degrees/radians angle modes.
 - π .
 - SIN, COS, TAN, ASIN, ACOS, ATAN.
 - Angle and coordinate conversions: degrees/radians, Hours.Decimal hours/Hours.Minutes Seconds, polar/rectangular coordinates (CONVERT menu).
- Probability functions: factorial, random number, combinations, permutations (PROB menu).
- Hyperbolic and inverse hyperbolic functions (HYP menu).
- Number-altering functions: absolute value, integer and fractional parts, rounding (PARTS menu).

Base conversions are covered in chapter 3.

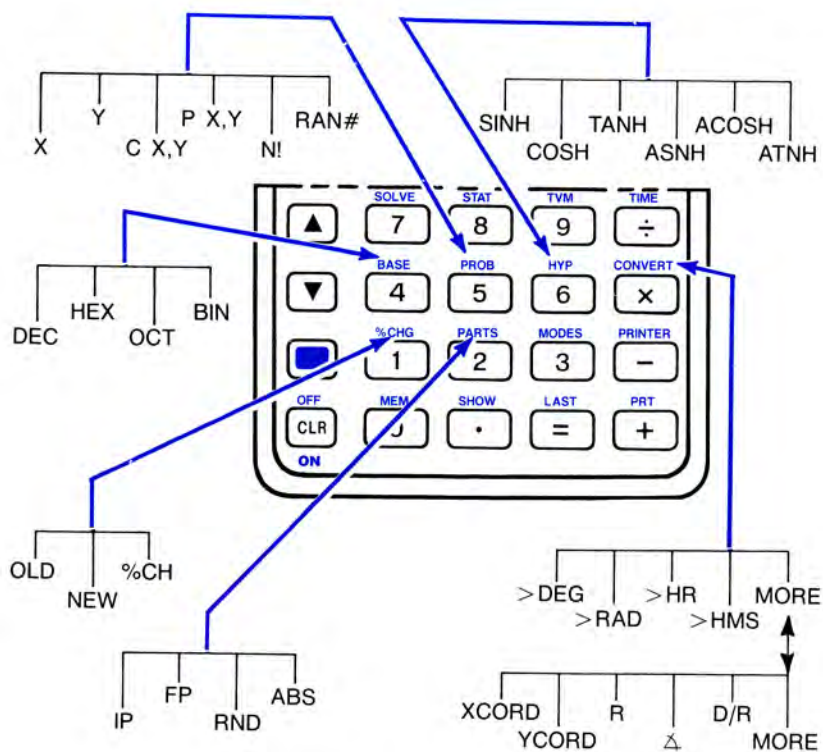

Figure 2-1. Numeric Function Menus

General Functions

x^2 , \sqrt{x} , and $1/x$ act on the rightmost number in the calculator line. You do not need to press \square when menu labels are absent.

Keys:	Display:	Description:
45 \sqrt{x}	6.7082	$\sqrt{45}$.
3 $1/x$ + 4 $1/x$	0.3333+0.2500	Calculates $1 \div 3$, $1 \div 4$.
=	0.5833	
125 y^x 3 $1/x$ =	5.00	Calculates cube root of 125.
\square MAIN 5.9 x^2	34.8100	No need to use \square before x^2 in MAIN display.

Percent. The $\square\%$ function performs two different operations:

- When there is only one number in the calculator line, or when the operator preceding the rightmost number is anything but + or -, $\square\%$ divides the rightmost number by 100.
- When + or - precedes the rightmost number, $\square\%$ interprets the rightmost number as a percentage, and returns that percent of the number preceding the + or -.

Keys:	Display:	Description:
85.3 \times 27 $\square\%$	85.3000 \times 0.2700	Divides 27 by 100.
=	23.0310	Calculates 27% of 85.3
200 \square 25 $\square\%$	200.0000-50.0000	Calculates 25% of 200.
=	150.0000	Completes the calculation.

Percent change. The %CHG menu does calculations based on the percent change between two numbers. The menu contains three variables—*OLD*, *NEW*, and %*CH*. If necessary, refer to page 29 for additional information about using variables in menus.

Calculate the percent difference between 291.7 and 316.8.

Keys:	Display:	Description:
%CHG		Displays %CHG menu.
291.7 OLD	OLD=291.7000	Stores <i>OLD</i> .
316.8 NEW	NEW=316.8000	Stores <i>NEW</i> .
%CH	%CHANGE=8.6047	Calculates percent change.

To do a percent change calculation in the middle of a chain calculation, you must use **STO** with the menu key (see the rules for using menu variables on page 29). The following keystrokes calculate $65 \times 12 \times$ the number 45% larger than 80.

65 x 12 x	780.0000x	
80 STO		Stores 80 in <i>OLD</i> .
OLD	780.0000x80.0000	
45 STO		Stores 45 in % <i>CH</i> .
%CH	780.0000x45.0000	
NEW	780.0000x116.0000	116 is 45% larger than 80.
=	90,480.0000	Completes the calculation.

Logarithmic Functions

The logarithmic functions use the rightmost number in the calculator line. You do not need to press \square before e^x and \square when the menu labels are absent.

Table 2-2. Logarithmic Functions

Keys	Function	Keys	Function
\square e^x	Natural antilogarithm.	\square 10^x	Base 10 antilogarithm.
\square LN	Natural logarithm.	\square LOG	Base 10 logarithm.

Show that multiplying numbers is equivalent to adding logarithms.

Keys:	Display:	Description:
47.5 \square LN	3,8607	Natural log of 47.5.
\square + 68.3 \square LN	3,8607+4,2239	Natural log of 68.3.
\square = \square e^x	3,244,2500	Natural antilogarithm of the sum.
47.5 \square x 68.3		Compare to previous result.
\square =	3,244,2500	

Trigonometric and Angle Functions

Trigonometric Mode. The two trigonometric modes—*Degrees* and *Radians*—determine how numbers are interpreted when using the trigonometric and coordinate conversion functions. Degrees mode assumes that all angles are measured in decimal degrees (rather than Degrees.MinutesSeconds). In Radians mode, all angles are measured in radians.

The radians annunciator **RAD** indicates Radians mode. Changing the trigonometric mode does not change numbers stored in the history stack or in variables.

To change the trigonometric mode:

1. Press **MODES**, then **MORE**.
2. Press **D/R**. Check for the presence or absence of the radians annunciator.
3. Press **EXIT**.

There is a second **D/R** key in the CONVERT menu.

π . Pressing **π** returns the 12-digit value of π , displayed in the current display format.

Find the surface area of a sphere with radius = 4.5 inches (surface area = $4\pi r^2$):

Keys:	Display:	Description:
4 x π	4.0000×3.1416	Displays π .
x 4.5 x^2	12.5664×20.2500	
=	254.4690	Surface area in square inches.

Trigonometric Functions. The trigonometric functions use the rightmost number in the calculator line. Angles are interpreted in decimal degrees or radians, depending on the current angle mode.

Table 2-3. Trigonometric Functions

Keys	Function	Keys	Function
SIN	sine	ASIN	arc sine
COS	cosine	ACOS	arc cosine
TAN	tangent	ATAN	arc tangent

If the **RAD** annunciator is on (indicating Radians mode), press

MODES **MORE** **D/R** to set Degrees mode.

Keys:	Display:	Description:
15 SIN	0.2588	Sine of 15°.
1 + 60 TAN =	2.7321	Calculates $1 + \tan 60^\circ$.
.35 ACOS - .62 ACOS =	69.5127-51.6839 17.8288	Arc cosine of .35 minus arc cosine of .62.

Angle and Hour Conversions. The angle and hour conversion are in the CONVERT menu. They use the rightmost number in the calculator line.

Table 2-4. Angle and Hour Conversion Functions

Menu Key	Function
>DEG	<i>To degrees; converts the number from a radian value to its decimal degree equivalent.</i>
>RAD	<i>To radians; converts the number a from decimal degree value to its radian equivalent.</i>
>HR	<i>To hours; converts the number from hours(degrees)-minutes-seconds-decimal seconds format (H.MMSSss or D.MMSSss) to decimal hours (or degrees) format.</i>
>HMS	<i>To hours-minutes-seconds; converts the number from decimal hours (or degrees) to hours(degrees)-minutes-seconds-decimal seconds format (H.MMSSss or D.MMSSss).</i>

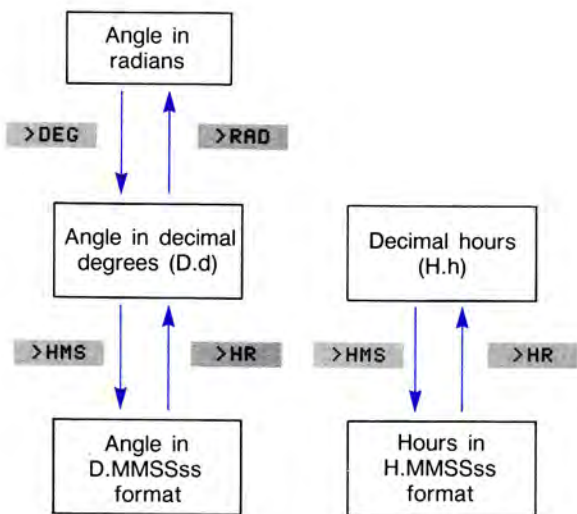

Keys:

1.79

90.2015

25.2589

Display:

5.6235

322.2000

90.3375

25.1532

FULL PRECISION IS:
 25.153204

Description:

Calculates 1.79π .

Converts 1.79π radians to degrees.

Converts 90 degrees, 20 minutes, 15 seconds to decimal degrees.

Converts to D.MMSSss format.

25 degrees, 15 minutes, 32.04 seconds.

Exits the CONVERT menu.

Polar and Rectangular Coordinate Conversions. The second page of the CONVERT menu provides a set of variables for converting between polar and rectangular coordinates.

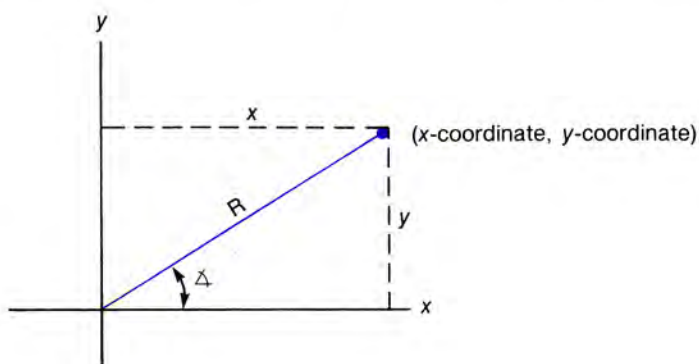

The angle is interpreted according to the current angle mode—decimal degrees or radians. The menu contains **D/R** for switching between Degrees and Radians modes. (The same key appears in the MODES menu; see page 53.)

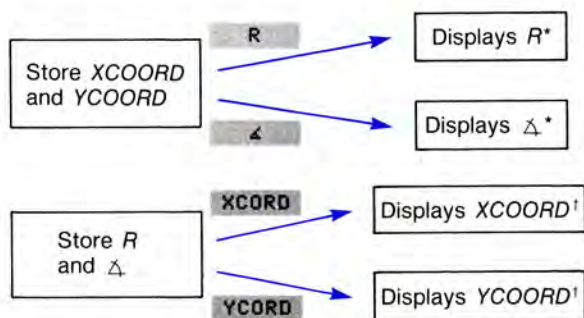

* Calculates both R and Δ .

† Calculates both $XCOORD$ and $YCOORD$.

Convert the rectangular coordinates (10, -15) to polar coordinates.

Keys:	Display:	Description:
CONVERT MORE		Displays the polar/rectangular conversion variables.

If the **RAD** annunciator is on, press **D/R** to set Degrees mode.

10 XCORD	XCOORD=10.0000	Stores x -coordinate.
15 +/- YCORD	YCOORD=-15.0000	Stores y -coordinate.
R	RADIUS=18.0278	Calculates R .
∠	∠=-56.3099	Calculates the angle.

To do coordinate conversions in the middle of a chain calculation, use **STO** in conjunction with the menu key. The following keystrokes add 12.734 + 9.231 + the x -coordinate of the vector ($r = 25$, $\Delta = 45^\circ$):

12.734 +		
9.231 +	21.9650+	
25 STO		Stores R .
R	21.9650+25.0000	
45 STO		Stores angle.
∠	21.9650+45.0000	
XCORD	21.9650+17.6777	Calculates x -coordinate.
=	39.6427	Completes the calculation.
EXIT		Exits the CONVERT menu.

Probability Functions

The PROB menu calculates combinations, permutations and factorials, and generates sequences of random numbers.

Combinations and Permutations. The number of *combinations* of x objects taken y at a time ($C_{x,y}$) is the number of different sets containing y items that can be taken from a larger group of x items. No item occurs more than once in the set of y items, and different orders of the same y items *are not* counted separately.

The number of *permutations* of x objects taken y at a time ($P_{x,y}$) is the number of different arrangements of y items that can be taken from a larger group of x items. No items can occur more than once in an arrangement, and different orders of the same y items *are* counted separately.

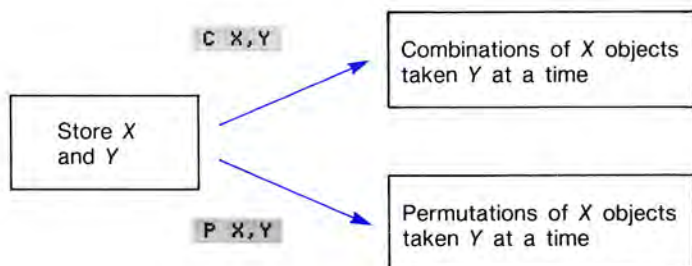

Keys:

PROB

5 **X**

3 **Y**

C X, Y

P X, Y

EXIT

Display:

X=5.0000

Y=3.0000

C X, Y=10.0000

P X, Y=60.0000

Description:

Displays the PROB menu.

Stores x .

Stores y .

Calculates combinations.

Calculates permutations.

Exits the PROB menu.

Random Number. Pressing **RAN#** displays a random number in the range $0 \leq \text{RAN\#} < 1$.*

When **RAN#** is pressed for the first time, the HP-27S uses the system clock to generate a *seed*—a number that initiates the sequence of random numbers. Pressing 0 **STO** **RAN#** uses a new seed from the system clock. To specify a particular seed, key in the seed (a non-zero number) and press **STO** **RAN#** to display the random number. You can repeat a random number sequence by storing the same non-zero seed.

Factorial. **N!** calculates the factorial of the rightmost number on the calculator line. The number must be an integer in the range 0 through 253.

Hyperbolic Functions

The HYP menu provides the hyperbolic functions. The functions use the rightmost number in the calculator line.

Table 2-5. Hyperbolic Functions

Menu Key	Function	Menu Key	Function
SINH	Hyperbolic sine	ASNH	Inverse hyperbolic sine
COSH	Hyperbolic cosine	ACOSH	Inverse hyperbolic cosine
TANH	Hyperbolic tangent	ATNH	Inverse hyperbolic tangent

Keys:

Display:

Description:

HYP 5

Hyperbolic sine.

SINH 74.2032

540.25 **ACOSH** 6.9852

Inverse hyperbolic cosine.

EXIT

Exits the HYP menu.

*The number is part of a sequence of uniformly distributed pseudo-random numbers. This sequence passes the spectral test (D. Knuth, *Seminumerical Algorithms*, Vol. 2, London: Addison Wesley, 1981).

Parts of Numbers

The functions in the PARTS menu use the rightmost number on the calculator line.

Table 2-6. The PARTS Menu

Menu Key	Function
IP	Integer part of the number.
FP	Fractional part of the number (the number without its integer part).
RND	Rounds the number internally to the number of digits specified in the current FIX, SCI, or ENG display mode (no rounding occurs in ALL mode).
ABS	Absolute value of the number.

Keys:

12.3456789 [=]

Display:

12.3457

Description:

Enters a nine-digit number.

[**SHOW**]

FULL PRECISION IS:
12.3456789

Displays full precision of number.

[**PARTS**]

[RND]

[**SHOW**]

FULL PRECISION IS:
12.3457

Number is rounded internally.

[EXIT]

Exits the PARTS menu.

Range of Numbers

Figure 2-2 illustrates the range of numbers the HP-27S can store. Underflow displays a warning, followed by 0. Overflow displays a warning and the largest positive or negative number possible.

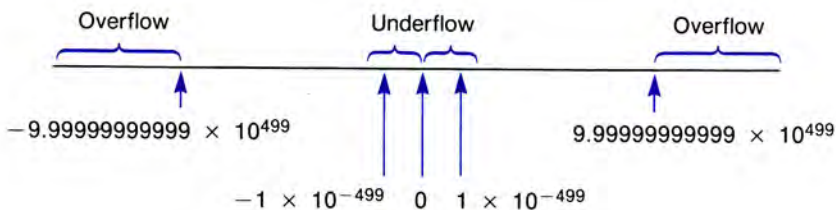



Figure 2-2. Range of Numbers

Base Conversions and Base Arithmetic

The BASE menu ( BASE) does operations with four number bases—DEC (decimal), HEX (hexadecimal), OCT (octal), and BIN (binary). The BASE menu converts numbers from one base to another and performs the arithmetic operations $+$, $-$, \times , and \div in any of the four bases.

When you press  BASE, DEC base is active, as indicated by the highlighted menu key.



Decimal base is active

Switching Bases

Press one of the menu keys in the BASE menu to switch to a new base. The menu key for the new base is highlighted, and numbers in the calculator line are converted to the new base. Switching to HEX base displays the HEX menu, which allows you to key in letters A through F. Exiting the HEX menu restores DEC base.

When you switch from DEC to any other base, the integer part of the number is displayed in the new base. Internally, the 12-digit representation of the decimal number is preserved. When you switch back to DEC base, the full decimal number is displayed, rounded to the current display format. Numbers are truncated to integers internally only when they are used in an arithmetic operation in HEX, OCT, or BIN base.

If a binary number is longer than 21 characters, the display shows the rightmost (least significant) 20 characters. Press **■** and then hold down **[SHOW]** to view the entire number in two lines with the most significant digits on the top line.

Example: Converting Between Bases. The following keystrokes do a series of base conversions.

Convert 125_{10} to binary, octal, and hexadecimal numbers:

Keys:	Display:	Description:
125 ■ [BASE]	125.0000	Displays the BASE menu. DEC base is active.
[BIN]	1111101	Converts 125_{10} to binary base.
[OCT]	175	Sets OCT base. $125_{10} = 175_8$.
[HEX]	7D	Sets HEX base. $175_8 = 7D_{16}$.
[EXIT]	125.0000	Restores DEC base.

Convert $24FF_{16}$ to binary base:

[HEX]		Sets HEX base.
24 [F] [F]	24FF	Keys in hexadecimal number.
[EXIT] [BIN]	10010011111111	Converts $24FF_{16}$ to BIN base.
[EXIT]	9,471.0000	Exits BASE menu; restores DEC base.

Representation of Numbers

Decimal numbers are stored internally as a 12-digit mantissa with 3-digit exponent. When a number is converted from its decimal value to HEX, OCT, or BIN base, the integer part of the number is represented as a 36-bit, binary number. The leftmost (most significant) bit is the sign bit; it is set (1) for negative numbers.

Negative numbers are represented internally as the 2's Complement of the positive binary number.

Keys:	Display:	Description:
<input type="button" value="BASE"/> 8738		
<input type="button" value="HEX"/>	2222	Converts $8,738_{10}$ to hexadecimal base.
<input type="button" value="+/-"/>	FFFFFFDDDE	2's Complement.
<input type="button" value="EXIT"/>	-8,738.0000	Negative decimal number.

Range of HEX, OCT, and BIN Numbers

The 36-bit word size determines the range of numbers that can be represented in HEX, OCT, and BIN bases, and the range of decimal numbers that can be converted to other bases.

Table 3-1. Range of Numbers for Base Conversions

Base	Largest Positive Integer	Largest Negative Integer
DEC	34,359,738,367	-34,359,738,368
HEX	7FFFFFFFF	800000000
OCT	37777777777	400000000000
BIN	11111111111111111111111111111111 11111111111111111111111111111111	10000000000000000000000000000000 00000000000000000000000000000000

When you key in numbers in HEX, OCT, or BIN base, digit entry halts if you attempt to key in too many digits. For example, if you attempt to key in a 10-digit hexadecimal number, digit entry halts and the HP-27S beeps after the ninth digit.

If the calculator line contains a decimal number outside the range in table 3-1, switching to HEX, OCT, or BIN base displays the message T00BIG.

Keys:	Display:	Description:
<input type="checkbox"/> MODES <input type="checkbox"/> SCI 0 <input type="checkbox"/> INPUT		Sets scientific format.
<input type="checkbox"/> BASE 1 <input type="checkbox"/> E 20 <input type="checkbox"/> OCT	T00BIG	1×10^{-20} cannot be converted to OCT base.
<input type="checkbox"/> DEC	1.E20	Restores DEC base.
3 <input type="checkbox"/> E 11 <input type="checkbox"/> - 3 <input type="checkbox"/> E 8 <input type="checkbox"/> HEX	T00BIG-11E1A300	3E11 cannot be converted to HEX base.
<input type="checkbox"/> MAIN	3.E11-3.E8	Exits BASE menu, restores DEC base.
<input type="checkbox"/> CLR <input type="checkbox"/> MODES <input type="checkbox"/> FIX 4 <input type="checkbox"/> INPUT	0.0000	Clears calculator line; sets display to four decimal places.





If the result of an arithmetic operation in HEX, OCT, or BIN base cannot be represented in 36 bits, the HP-27S displays the overflow warning, followed by the largest (or smallest) number possible.

Arithmetic Operations

The arithmetic operations $\boxed{+}$, $\boxed{-}$, $\boxed{\times}$, $\boxed{\div}$, and $\boxed{\wedge}$ can be performed in any of the four bases. All operations use 2's Complement arithmetic. Operations with HEX, OCT, or BIN bases use integers only.

When a division in HEX, OCT, or BIN base produces a remainder, only the integer portion of the number is retained.

Example: Arithmetic in HEX, OCT, and BIN Bases. Calculate $12F_{16} + E9A_{16}$:

Keys:	Display:	Description:
 BASE		Sets HEX base.
 HEX		
$12F \boxed{+} E9A \boxed{=}$	FC9	Adds hexadecimal numbers.
Calculate $7760_8 - 4326_8$:		
 EXIT	4,041.0000	Exits HEX menu, switches to DEC base ($FC9_{16} = 4041_{10}$).
 OCT	7711	Switches to OCT base ($4041_{10} = 7711_8$).
$7760 \boxed{-} 4326 \boxed{=}$	3432	
Calculate $100_8 \div 5_8$:		
$100 \boxed{\div} 5 \boxed{=}$	14	Integer part of result.

Compare the previous result to the decimal division shown below:

100 \div 5

DEC 64.0000 \div 5.0000

Converts operands to decimal base.

= 12.8000

OCT 14

Displays integer portion of 12.8₁₀ in OCT base.

Add 5A0₁₆ plus 1001100₂.

HEX 5A0 5A0

Keys in HEX base number.

EXIT

BIN 10110100000

Switches to BIN base.

+ 1001100 = 10111101100

Calculates result in BIN base.

Arithmetic results that cannot be represented in 36 bits display an overflow warning and the largest positive or smallest negative number:

HEX 5EC

Switches to HEX base.

5AAAAAAAA

x 4 = OVERFLOW
7FFFFFFFF

Largest positive number.

EBBBBBBBB

-
6CCCCCCC
= OVERFLOW
800000000

Smallest negative number.

Statistics

The STAT application does one- and two-variable statistics calculations using sets of data called *number lists*. As numbers are entered into a list, the HP-27S displays the running total. Once a list has been entered, you can:

- Calculate the mean, median, standard deviation, maximum, minimum, and/or range (largest minus smallest) of the numbers in the list.
- Sort the list from smallest to largest number.

The following calculations use two number lists:

- Curve fitting and estimation calculations with four models—linear (linear regression), exponential, logarithmic, and power.
- Weighted mean and grouped standard deviation.
- Summation statistics— Σx , Σx^2 , Σy , Σy^2 , and Σxy .

The number of lists you can store and their sizes are limited only by the amount of available memory.

Entering the STAT Application

To enter the STAT application, press **▣** **STAT**. Table 4-1 describes the STAT menu.

Table 4-1. The STAT Menu

Menu Keys	Description
CALC	Displays the CALC menu for doing statistical calculations.
INSR	Inserts numbers into the list.
DELET	Deletes numbers from the list.
NAME	Names or renames the list.
GET	Switches from one list to another and creates new lists.
TOTAL	Erases the STAT menu and displays the total in the calculator line.

When you enter the STAT application, you are viewing the first empty item in a particular number list. This list is called the *current list*. If there are no lists in memory, the current list is empty and the HP-27S “prompts” you for the first item:

ITEM(1)=?

If there are lists already in memory, the current list is the one you worked with most recently. You will be viewing the bottom of the list. For example, if the current list contained 50 numbers, you would see:

ITEM(51)=?

When the STAT menu is displayed, pressing a digit key, **INPUT**, or **TOTAL** erases the menu and displays the calculator line. To restore the STAT menu, press **EXIT**.

Entering Data and Calculating the Running Total

Generally, a new set of data is stored into an empty list. If the current list already contains data, you can make an empty list available in two ways:

- Clear the current list by pressing **CLEAR DATA** **YES** (see page 76 for additional information).
- Create a new, empty list by pressing **GET** ***NEW** (see page 75 for additional information).

To enter data into an empty list:

1. Key in the first number or expression (for example, 2 **×** 75). During number entry, the calculator line replaces the STAT menu. (You can restore the STAT menu by pressing **EXIT**.)

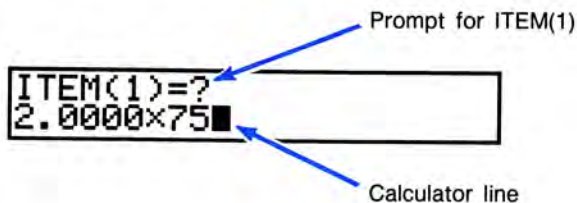

2. Press **INPUT** to enter the number. If the calculator line contains an expression (for example, 2.0000×75), the expression is evaluated and the result is entered into the list. The HP-27S displays the running total and a prompt for the next item.



- Repeat steps 1 and 2 to enter all the data. The calculator recognizes the end of a list when an item is left blank.
- Press **EXIT** to restore the STAT menu.

Viewing and Editing the List

▲ and **▼** move up and down the list. **■▲** and **■▼** display the beginning and end of the list. Moving up and down the list does not affect the value of the running total.

Changing a Number. To change a number in the list:

- Use the arrow keys to locate and display the incorrect value.
- Key in the correct value and press **INPUT**.

Inserting a Number. To insert an item:

- If necessary, press **EXIT** to restore the STAT menu.
- Use the arrow keys to locate and display the place of insertion. For example, to insert a number between ITEM(6) and ITEM(7), display ITEM(7).
- Press **INSR** to insert a new item, which is initially set to 0.
- Key in the value for the item and press **INPUT**.

Deleting a Number. To delete a number:

- If necessary, press **EXIT** to restore the STAT menu.
- Use the arrow keys to locate and display the item to be deleted.
- Press **DELET**.

Example: Updating a Checkbook. On May 31, a checking account balance was \$267.82. The transactions for the first 10 days in June are:

Date	Transaction	Amount	Date	Transaction	Amount
5/31	Balance	267.82	6/3	Check	-128.90
6/1	Deposit	837.42	6/7	Check	-65.35
6/1	Check	-368.23	6/10	Deposit	55.67
6/2	Check	-45.36			

Update the checkbook by calculating the running balance.

Keys:

Display:

Description:

MODES

FIX

2 **INPUT**

STAT

Sets display to two decimal places.

Enters the STAT application.

If you want to preserve the current list, skip the next step. Instead, name the list and then press **GET** ***NEW**.

CLEAR DATA

YES

267.82 **INPUT**

837.42 **INPUT**

ITEM(1)=?

ITEM(2)=?
TOTAL=267.82

ITEM(3)=?
TOTAL=1,105.24

Clears the list.

Enters beginning balance.

Enters deposit on 6/1.

368.23

45.36

128.9

65.35

55.67

ITEM(8)=?

TOTAL=553.07

ITEM(8)=?

4

Enters remaining transactions.

Restores the STAT menu.

Restores four decimal places.

Copying a List Number to the Calculator Line

To copy a number from the list to the calculator line, display the item and press .

Naming and Renaming a List

Naming lists allows you to have more than one list in memory. A list must be named or cleared before you can switch to a different list.

To name or rename the current list:

1. Press .
2. Type (or edit) the name. (Typing alphabetic information is covered on pages 36 through 40).
3. Press .

List names can be up to 22 characters long and should not contain any of the following characters: +, -, ×, ÷,), (, <, >, ^, :, =, and space.* The first three to five characters (some letters are wider than others) become a menu label when you press **GET** to switch lists. For example, if memory contains three lists named RATE, AREA, and CHECKBOOK, pressing **GET** displays:

```
SELECT A NAME
*NEW RATE AREA CHEC
```

To view the name without making any changes, press **NAME**, then **EXIT**.

Switching Lists and Creating New Lists (GET)

To switch to a different list or create a new list:

1. If you haven't already done so, name the current list.
2. Display the STAT menu and press **GET**. The GET menu contains a menu label for each named list, plus ***NEW**.
3. Press the appropriate menu key. ***NEW** displays a new, empty list.

Figure 4-1 illustrates switching between two lists named *JANCHECKS* and *FEBCHECKS*, creating a new list, and naming that list.

* **NAME** will accept names containing these characters. However, names containing these characters cannot be used as the *listname* parameter in the Solver **SIZES** and **ITEM** functions.

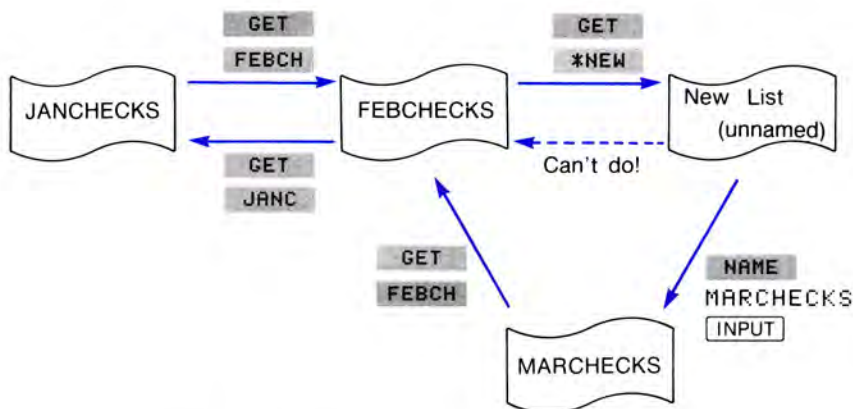

Figure 4-1. Switching Between Number Lists

Clearing a List

Clearing a number list erases all the data. The memory used by the list becomes available for other information.

To clear the current list, press **■** **CLEAR DATA**, then **YES**. If the list is named, the HP-27S lets you choose whether or not to clear the name by displaying:

ALSO CLEAR LIST NAME?

Pressing **YES** displays an empty, nameless list. Pressing **NO** retains the name, and you will be viewing the empty, named list.

One-Variable Statistics

Press **CALC** to display the CALC menu, which is described in table 4-2. All the menu keys except **FRCST** use the current list.

Table 4-2. The STAT CALC Menu

Menu Key	Description
TOTAL	Calculates the sum of the numbers in the list.
MEAN	Calculates the arithmetic mean (average) of the numbers in the list.
MEDN	Calculates the median.
STDEV	Calculates the <i>sample</i> standard deviation.* The standard deviation is a measure of how dispersed the numbers are about the mean.
RANG	Calculates the difference between the largest and smallest number.
	
MIN	Displays the smallest number in the list.
MAX	Displays the largest number in the list.
SORT	Sorts the list from smallest to largest number.
FRCST	Displays a series of menus for calculations based on two number lists (curve fitting, estimation, weighted mean and grouped standard deviation, summation statistics).

* The HP-27S calculates the *sample standard deviation*, which assumes the list of numbers is a sampling of a larger, complete set of data. If the list is the entire set of data, the *true population standard deviation* can be computed by calculating the mean of the original list, placing that value into the list, and then calculating the standard deviation. If you later edit the list, you must delete the old mean from the list, calculate a new mean, and enter the new mean into the list in order to calculate the new true population standard deviation.

Example: One-Variable Statistics Calculations. Production supervisor May Kitt wants to determine how long a certain process takes. She randomly picks ten people, observes each one as they carry out the process, and records the number of minutes required:

15.5	9.25	10.0	14.75	11.25
12.5	12.0	8.5	13.0	12.25

Calculate the mean, range, and standard deviation of the times, and display the longest time. Also name the list **TASK**.

Keys:

Display:

Description:

Enters the **STAT** application.

If you want to preserve the current list, skip the next step. Instead, name the list and then press .

Clears the list.

ITEM(1)=?

15.5

ITEM(2)=?

TOTAL=15.5000

Enters the first time.

9.25

ITEM(3)=?

TOTAL=24.7500

Enters the second time.

10

14.75

11.25

12.5

12

8.5

13

12.25

ITEM(11)=?

TOTAL=119.0000

Enters the remaining data.

119.0000

Displays the **CALC** menu.

MEAN=11.9000

Calculates mean.

STDEV=2.2460

Calculates standard deviation.

RANGE=7.0000

Calculates largest minus smallest number.

MAX=15.5000

Displays largest number.

EXIT	ITEM<11>=?	Displays STAT menu.
NAME	TASK	Names the list TASK.
INPUT	ITEM<11>=?	

Statistics Operations With Two Lists

These statistics operations use two lists, and are available in the FRCST menu:

- Curve fitting for the linear, logarithmic, exponential, and power models.
- Summation statistics— Σx , Σx^2 , Σy , Σy^2 , Σxy .
- Mean and standard deviation for grouped data (weighted mean and grouped standard deviation).

When you press **FRCST**, the HP-27S requires you to specify two previously created lists—one for the x -variable and one for the y -variable. The two lists must have the same number of items. Table 4-3 describes the contents of these lists.



Table 4-3. Two-List Operations

Calculation	Contents of the List Designated the X-Variable	Contents of the List Designated the Y-Variable
Curve fitting and estimation, summation statistics	x -values	y -values
Weighted mean	Numbers	Weights of numbers or frequencies with which the numbers occur (integer or non-integer).
Grouped standard deviation	Numbers	Frequency with which the numbers occur (integer only*).

* No error occurs for non-integer frequencies, but in most cases the calculated grouped standard deviation is not meaningful.

Table 4-4 describes the FRCST menu. The next sections describe two-list calculations in more detail.

Table 4-4. The FRCST Menu

Menu Key	Description
<i>x</i> -variable <i>y</i> -variable	Used for estimation calculations. Store <i>x</i> and calculate <i>y</i> or vice versa.*
CORR *	Displays the <i>correlation coefficient</i> . The correlation coefficient is a number in the range -1 through $+1$ that measures how closely the data fits the calculated curve. A value of $+1$ indicates a perfect positive correlation, -1 indicates a perfect negative correlation. A value close to 0 indicates the curve is a poor fit.
M *	Displays <i>M</i> . For the linear model, this is the slope.
B *	Displays <i>B</i> . For the linear model, this is the <i>y</i> -intercept.
	
MODL	Displays a choice of the four curve fitting models.
W.MN	Calculates the weighted mean of the <i>x</i> -values using the <i>y</i> -values as weights (or frequencies).
G.SD	Calculates the standard deviation of a set of numbers (<i>x</i> -values) occurring with the specified integer frequencies (<i>y</i> -values).
SIZE	Displays the number of items in each list.
	
ΣX	Calculates the sum (total) of the <i>x</i> -values.
ΣY	Calculates the sum (total) of the <i>y</i> -values.
ΣX ²	Calculates the sum of the squares of the <i>x</i> -values.
ΣY ²	Calculates the sum of the squares of the <i>y</i> -values.
ΣXY	Calculates the sum of the products of the <i>x</i> - and <i>y</i> -values.
* Calculated using the transformed equations for the exponential, logarithmic, and power models (see table 4-5 on page 82).	

Linear Regression, Curve Fitting, and Estimation

Curve fitting is a statistical method for finding a relationship between two variables— x and y . You can select one of four curve-fitting models (see figure 4-2). For each model, the HP-27S computes M , B and the correlation coefficient. You can also estimate y for a given x and vice versa.

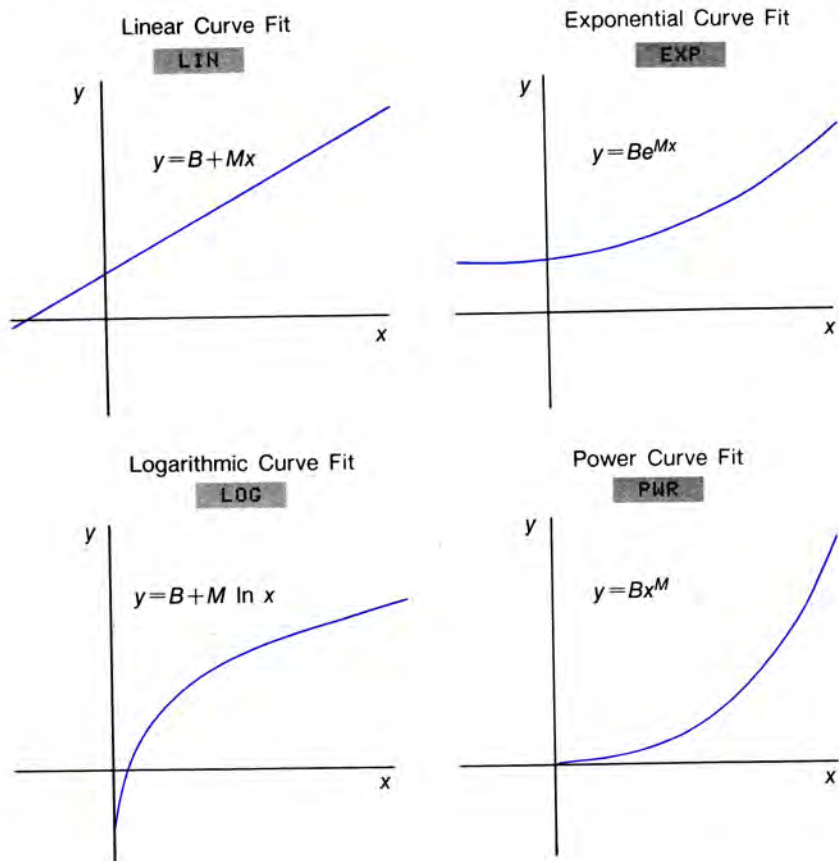

Figure 4-2. Curve Fitting Models

Table 4-5 describes the models in more detail. When curve fitting uses the linear model, the calculation is called *linear regression*. Calculations for the exponential, logarithmic, and power models use transformations that allow the data to be fitted by standard linear regression.

Table 4-5. Curve Fitting Models

Model	Equation	Transformation	Constraints
Linear	$y = B + Mx$	None	None
Logarithmic	$y = B + M \ln x$	$y = B + M \ln x$ y versus $\ln x$.	$x > 0$
Exponential	$y = Be^{Mx}$	$\ln y = \ln B + Mx$ $\ln y$ versus x .	$y > 0$
Power	$y = Bx^M$	$\ln y = \ln B + M \ln x$ $\ln y$ versus $\ln x$	$x > 0, y > 0$

To do curve fitting and estimation:

1. Enter the data into two STAT lists—one for the x -values and one for the y -values. The two items in an x,y pair must have the same item number in each list. Give both lists meaningful names. (You do not need to name the current list, but naming it avoids possible confusion later.)
2. From the STAT menu, press **CALC**, then **MORE**.
3. Press **FRCST** to display a menu of list names. To select the x -variable, press the appropriate menu key. (If the current list is unnamed, pressing ***CURR** selects it.)
4. Select the y -variable by pressing another menu key. The HP-27S displays the FRCST menu and the current model.
5. If you need to change models, press **MORE** **MODL**, and then press a menu key to select a model.
6. To display the curve fitting results, press **CORR**, **M**, and/or **B**.
7. To do estimation calculations:
 1. Key in the known value and press its menu key.
 2. Press the menu key for the unknown.

Example: Curve Fitting and Estimation Calculations. The rate of a certain chemical reaction depends on the initial concentration of one chemical. When the reaction is run repeatedly, varying only the initial concentration of the chemical, the following rates are observed:

X	Concentration (moles per liter)	.050	.075	.10	.125	.20
Y	Rate (moles per liter-seconds)	.00620	.00941	.0140	.0146	.0230

Assuming a linear relationship, calculate the correlation coefficient and slope of the line. Use linear estimation to calculate the rate of the reaction when the concentration equals 0.09 moles/liter.

Keys:	Display:	Description:
<input type="button" value="STAT"/>		Displays the STAT menu.
If you want to preserve the current list, skip the next step. Instead, name the list and then press <input type="button" value="GET"/> <input type="button" value="*NEW"/> .		
<input type="button" value="CLEAR DATA"/>		Clears the current list.
<input type="button" value="YES"/>	ITEM<1>=?	
.05 <input type="button" value="INPUT"/>		Enters the concentration data.
.075 <input type="button" value="INPUT"/>		
.1 <input type="button" value="INPUT"/>		
.125 <input type="button" value="INPUT"/>		
.2 <input type="button" value="INPUT"/>	ITEM<6>=? TOTAL=0.5500	
<input type="button" value="EXIT"/>		Displays the STAT menu.
<input type="button" value="NAME"/>		Names the list CONC.
CONC <input type="button" value="INPUT"/>	ITEM<6>=?	
<input type="button" value="GET"/>		Switches to a new, empty list.
<input type="button" value="*NEW"/>	ITEM<1>=?	

.0062	INPUT		Enters the rate data.
.00941	INPUT		
.014	INPUT		
.0146	INPUT		
.023	INPUT	ITEM(6)=? TOTAL=0.0672	
EXIT		ITEM(6)=?	Displays the STAT menu.
NAME			Names the list RATE.
RATE	INPUT	ITEM(6)=?	
CALC			
MORE			
FRCST		SELECT X VARIABLE	
CONC		SELECT Y VARIABLE	Specifies the list containing the x -values.
RATE		<i>model</i>	Specifies the list containing the y -values.

Do the following step if the current model is *not* linear:

MORE			Selects the linear model.
MDDL			
LIN			
CORR		CORR=0.9890	Calculates the correlation coefficient.
M		M=0.1093	Calculates the slope.
.09	CONC	CONC=0.0900	Stores CONC for estimation calculation.
RATE		RATE=0.0113	Calculates the estimated rate.

Weighted Mean and Grouped Standard Deviation

The following procedure calculates the weighted mean and grouped standard deviation. The weighted mean is the mean of data points x_1, x_2, \dots, x_n occurring with weights w_1, w_2, \dots, w_n . The weights can be non-integer or integer values (frequencies). Grouped standard deviation is the standard deviation of data points x_1, x_2, \dots, x_n occurring at non-negative integer frequencies f_1, f_2, \dots, f_n .

To calculate weighted mean and/or grouped standard deviation:

1. Enter the data into two STAT lists—one for the numbers and one for the weights or frequencies. The number and its weight (frequency) must have the same item number in each list. Give both lists meaningful names. (You do not need to name the current list, but naming it avoids possible confusion later.)
2. From the STAT menu, press **CALC** , then **MORE** .
3. Press **FRCST** . Designate the list containing the numbers as the x -variable by pressing the appropriate menu key. (If the current list is unnamed, pressing ***CURR** selects it.)
4. Designate the list containing the weights or frequencies as the y -variable by pressing the appropriate menu key. Ignore the message indicating the current model.
5. Press **MORE** .
6. To calculate the weighted mean, press **W.MN** . To calculate the grouped standard deviation, press **G.SD** .

Example: Weighted Mean and Standard Deviation of Grouped Data. Your manufacturing company purchases a certain part four times a year. Last year's purchases were:

Price/Part	\$4.25	\$4.60	\$4.70	\$4.10
Number of Parts	250	800	900	1000

The number of parts for each price is the frequency with which each price occurred. Therefore, you can calculate both the weighted mean and the grouped standard deviation.

Keys:	Display:	Description:
<input type="button" value="STAT"/>		Displays the STAT menu.

If you want to preserve the current list, skip the next step. Instead, name the list and then press .

<input type="button" value="CLEAR DATA"/>		Clears the current list.
<input type="button" value="YES"/>	ITEM(1)=?	

4.25 <input type="button" value="INPUT"/>		Enters the numbers.
4.6 <input type="button" value="INPUT"/>		
4.7 <input type="button" value="INPUT"/>		
4.1 <input type="button" value="INPUT"/>	ITEM(5)=?	
	TOTAL=17.6500	

Displays the STAT menu.

Names the list PRICE.

PRICE

ITEM(5)=?

Switches to a new, empty list.

ITEM(1)=?

250

Enters the weights (frequencies).

800

900

1000

ITEM(5)=?

TOTAL=2,950.0000

ITEM(5)=?

Displays the STAT menu.

Names the list WEIGHT.

WEIGHT

ITEM(5)=?

SELECT X VARIABLE

PRICE	SELECT Y VARIABLE	Specifies list containing the prices.
WEIG	<i>model</i>	Specifies list containing the frequencies.
MORE		Calculates weighted mean.
W.MN	W.MN=4.4314	
G.SD	G.SD=0.2641	Calculates grouped standard deviation.

Summation Statistics

The FRCST menu includes keys for calculating Σx , Σy , Σx^2 , Σy^2 , and Σxy . Σx and Σy are equivalent to the total (*TOTAL*) of each list. For calculations involving only one variable, the same list can be designated the x - and y -variable (see the following example).

Example: Summation Statistics. Calculate Σx and Σx^2 for the following values of x : 2.345, 3.456, 4.567.

Keys:	Display:	Description:
STAT		Displays the STAT menu.
If you want to preserve the current list, skip the next step. Instead, name the list and then press GET *NEW .		
CLEAR DATA		Clears the current list.
YES	ITEM(1)=?	
2.345 INPUT		Enters data.
3.456 INPUT		
4.567 INPUT	ITEM(4)=? TOTAL=10.3680	
EXIT CALC		
MORE		
FRCST	SELECT X VARIABLE	

*CURR

*CURR

MORE

MORE

ΣX

$\Sigma X = 10.3680$

ΣX^2

$\Sigma X^2 = 38.3005$

Selects current list as x -
and y -variables.

Calculates total (same as
previous *TOTAL*).

Calculates Σx^2 .

The Equation Solver

The SOLVE application, or Solver, lets you store equations and solve each equation for any variable. The Solver simplifies equation-solving by creating a menu consisting of the variables in the equation. Values are stored and calculated using the rules for menu variables covered in chapter 1 (see page 29). For example, you can enter the equation of motion for free-fall:

$$\text{DISTANCE} = V_0 \times \text{TIME} - .5 \times G \times \text{TIME}^2$$

and solve for *DISTANCE*, *V0* (velocity at $t=0$), *G* (acceleration of gravity), or *TIME* when three values are known.

The number of equations you can store and the number of variables in each equation are limited only by the amount of available memory. The complexity of equations the Solver can interpret is increased by the availability of the numeric functions in table 5-3 starting on page 98.

Example: The Equation of Motion for Free-Fall. How far does an object fall in 5 seconds? How long does it take for an object to fall 500 meters? (The acceleration of gravity is 9.8067 meters/second².)

1. Press **SOLVE**, then **NEW**.
2. Type $\text{DISTANCE} = V_0 \times \text{TIME} - .5 \times G \times \text{TIME}^2$ **INPUT**.* (If necessary, see page 36 for instructions on using the ALPHA menu.)
3. Press **CALC**, then do these keystrokes:

* To type ^, press **Y**.

Keys:	Display:	Description:
9.8067 G	G=9.8067	Stores the constant.
0 V0	V0=0.0000	Stores <i>V0</i> .
5 TIME	TIME=5.0000	Stores <i>TIME</i> .
DISTA	DISTANCE=-122.5838	Calculates the number of meters the object falls.

How long does it take for the object to fall 500 meters?

500 +/-		Stores <i>DISTANCE</i> .
DISTA	DISTANCE=-500.0000	
TIME	TIME=10.0981	Iterative solution for <i>TIME</i> .

During the *iterative* solution for *TIME*, the Solver displays a series of estimates. See page 110 for additional information about iterative solutions.

Entering the SOLVE Application

To enter the Solver, press **[SOLVE]**. If there are no equations in memory, the HP-27S displays the SOLVE menu and a message:

```
(NEW) FOR NEW EQUATION
CALC EDIT DELET NEW
```

SOLVE menu

Type a new equation

If the equation list contains one or more equations, the HP-27S displays the *current equation*.

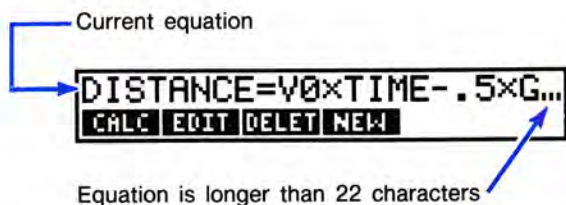

To designate another equation as the current equation, press \blacktriangle or \blacktriangledown until that equation is displayed.

Table 5-1. The SOLVE Menu

Menu Key	Description
CALC	Verifies the current equation and displays the menu of variables.
EDIT	Displays the ALPHA-edit menu and cursor for editing the current equation; also allows you to view the entire equation when it is longer than 22 characters.
DELET	Deletes the current equation and/or its variables.
NEW	Displays the ALPHA menu for entering a new equation. The equation is inserted below the previous current equation.

Entering Equations

To enter an equation:

1. Press \blacksquare **SOLVE**.
2. If the list is empty, or if the location of the new equation isn't important, go to step 3. To insert the equation at a particular place, use \blacktriangle or \blacktriangledown to display the equation that will be above the new equation. Pressing $\blacksquare\blacktriangle$ or $\blacksquare\blacktriangledown$ moves to the top or bottom of the list.
3. Press **NEW** to display the ALPHA menu.

4. Type the equation. If necessary, use  and the ALPHA-edit menu to correct typographical errors and to view portions of the equation that have scrolled off the display. (See page 36 for information about the ALPHA and ALPHA-edit menus.)
5. Press **INPUT** to enter the equation.

Doing Solver Calculations

Press **CALC** to verify the current equation and display the menu of its variables.

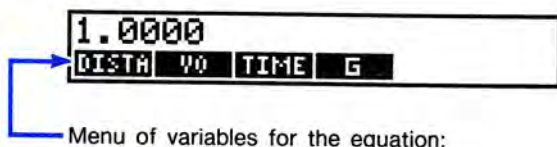

Menu of variables for the equation:

$$\text{DISTANCE} = V0 \times \text{TIME} - .5 \times G \times \text{TIME}^2$$

During verification, the Solver looks for syntax errors—missing operators, unmatched parentheses, misspelled functions, illegal variable names, etc. If the equation passes verification, the HP-27S displays the menu of variables. The value of new variables is set to 0.

If the equation breaks any syntax rules, the HP-27S briefly displays **INVALID EQUATION** and then displays the equation with the cursor positioned where an error was first detected.

To solve for a variable:

1. Store a value in all but one of the variables. To store each value, key in the number and press the appropriate menu key.
2. Optional: After entering all the known values (step 1), enter one or two guesses for the answer. To enter each guess, key in the value and press the menu key for the unknown. For example, **0 TIME 20 TIME** enters 0 and 20 as guesses for *TIME* (see page 112 for additional information about guesses).
3. To start the calculation, press the menu key for the unknown. If the Solver finds a solution, the answer is displayed on the calculator line.

In most cases, the Solver displays an answer. However, the Solver can deal with a wide variety of complex mathematical conditions. During certain calculations, the Solver displays sets of changing numbers. (If necessary, you can halt these calculations by pressing any key except **■**). The Solver may also display additional information at the conclusion of the calculation to help you analyze the result. "How the Solver Works" (see page 110) explains how to interpret information displayed by the Solver.

Clearing Solver Variables

To clear the variables in an equation, press **■** **CLEAR DATA** while the menu of variables is displayed. Clearing variables sets them equal to 0.

Variables are cleared when the equation is edited.

Viewing and Editing the Equation

Press **EDIT** to display the ALPHA-edit menu and cursor. You can use the cursor movement keys to scroll through the equation. If necessary, use the ALPHA-edit and ALPHA menus to make any changes (see page 36 for additional information about alpha entry and editing).

If you've edited the equation, press **INPUT** to replace the old version of the equation with the edited version. To return to the SOLVE menu without changing the stored equation, press **EXIT**.*

Editing an equation clears its variables.

* The HP-27S helps prevent loss of an edited equation. If you make changes and press **EXIT** without pressing **INPUT**, the HP-27S gives you another opportunity to save the edited equation.

Naming an Equation

Naming an equation helps you identify it. The name precedes the equation and is separated from the equation by a colon. Names can be any length and can include any characters except +, -, ×, ÷,), (, <, >, ^, :, =, and space. The name can be typed in as you initially enter the equation, or it can be added later using **EDIT**.

Equation name

FREEFALL: DISTANCE = $V_0 \times \dots$
CALC EDIT DELET NEW

Shared Solver Variables

If a variable appears in more than one Solver equation, that variable is *shared* among those equations. A value stored or calculated for that variable remains in memory until a new value is stored or calculated, or until the variable is cleared or deleted. Switching menus does not affect the stored value.

No sharing occurs between Solver variables and built-in variables contained in menus outside the Solver. For example, a variable *N* in a Solver equation is not shared with the variable *N* in the TVM application.

Example: Temperature Conversions Using Shared

Variables. Convert 350°F to degrees Kelvin, using the equations:

$$F = 9 \times C \div 5 + 32 \quad \text{and} \quad K = C + 273.16$$

where *F*, *C*, and *K* are degrees Fahrenheit, Celsius, and Kelvin.

1. Press **SOLVE** to enter the Solver application, then **NEW**.
2. Type the equation *F*/*C*: $F = 9 \times C \div 5 + 32$ **INPUT**.
3. Press **NEW** and type the equation *K*/*C*: $K = C + 273.16$ **INPUT**.
4. Press **CALC** to designate *F*/*C* as the current equation and display its menu of variables.

Keys:	Display:	Description:
350 F	F=350.0000	
C	C=176.6667	Calculates °C.
EXIT ▼		Displays the menu of variables for K/C.
CALC		
K	K=449.8267	Calculates degrees Kelvin using the value already stored in C.

Deleting the Current Equation and/or Its Variables

To delete the variables in an equation, or the equation *and* its variables, press **DELETE**. If the equation is using memory for its variables, the HP-27S displays DELETE THE VARIABLES?. You can respond **YES** or **NO**. You cannot delete an equation without first deleting its variables.

When the variables have been deleted, the HP-27S displays DELETE THE EQUATION?. Pressing **NO** retains the equation. The next time you display the menu of variables, memory is reallocated to them.

When a shared variable is deleted, its value is lost to any other equations that share the variable.

Deleting All Equations and/or Their Variables

To delete all Solver variables or all the equations *and* their variables, display the SOLVE menu (the top-level menu in SOLVE) and press **CLEAR DATA**. The HP-27S displays DELETE ALL VARIABLES?. Pressing **YES** deletes *all* the variables in *all* the equations. When all Solver variables have been deleted, the HP-27S displays DELETE ALL EQUATIONS?, allowing you to choose whether or not to delete all the equations.

The Syntax of Equations

When you press **CALC** to create the menu of variables, the Solver inspects the syntax of the equation. If any rules of syntax are broken, the HP-27S displays the message **INVALID EQUATION** and the **ALPHA**-edit menu.

The following terms are used to discuss equation syntax:

- *Variables* are the named knowns and unknowns—for example, *V0*, *TIME*, and *DISTANCE*.
- *Constants* are numbers.
- *Operators* are $+$, $-$, \times , \div , and \wedge .
- *Functions* do calculations using the arguments enclosed in parentheses—for example, $\text{SQRT}(X)$, $\text{XCOORD}(R:\Delta)$. When a function has more than one argument, the arguments are separated by a colon. Functions are described in the next section.

Equations must obey the following syntax rules:

- Equation length is limited only by the amount of available memory.
- Variable names contain a maximum of 10 characters. Names cannot begin with a number or decimal point. The characters $+$, $-$, \times , \div , \wedge , $($, $)$, $<$, $>$, $=$, $:$, and space cannot be used in variable names.
- The first four or five characters of the variable names become menu labels in the menu of variables. Therefore, make sure no two variables have the same first four or five characters.
- Constants must be keyed in as numbers without digit separators or other characters.

- Algebraic expressions are interpreted according to the operator priorities covered on pages 43 and 44. The priorities are expanded to include functions and their arguments:

: (separating arguments in functions)

Expressions inside parentheses

Functions (for example, SIN, ABS, RADIUS)

y^x

\times \div

$+$ $-$

NOT

AND

OR XOR

Highest Priority



Lowest Priority

For example:

$A \times B^3 = C$ is interpreted as $A \times B^3 = C$. To raise $A \times B$ to the 3rd power, enter $\langle A \times B \rangle^3 = C$.

$A + B \div C = 12$ is interpreted as $A + (B \div C) = 12$. To divide the sum of $A + B$ by C , enter $\langle A + B \rangle \div C = 12$.

In interpreting $\text{XCOORD}\langle T + 12 : A - 90 \rangle^2$, the Solver evaluates the arguments $T + 12$ and $A - 90$, computes the value of the function, and then squares the function value.

- You cannot use parentheses for implied multiplication. For example, the expression $P(1 - F)$ must be entered as $P \times \langle 1 - F \rangle$. The \times operator must be inserted between P and the parenthesis.
- You can use spaces to make the equation more readable as long as there are no spaces within variable names and function names.
- Equations can use any of the functions listed in table 5-3 starting on page 98.
- You cannot use logical operators (see table 5-4 on page 103) as variable names. For example, you cannot name a variable *AND*, but *CANDY* and *LAND* are acceptable variable names.

Solver Functions

Table 5-3 lists the Solver functions. The function arguments can be constants, variables, or algebraic expressions.























If a typing aid exists for the function, it is accessed by the same key-strokes used to execute the function in calculator-line arithmetic. For example,   displays ABS(.).











Table 5-3. Solver Functions

Function	Description	Typing Aid
ABS(x)	Absolute value.	 
ACOS(x)	Arc cosine.†	
ACOSH(x)	Hyperbolic arc cosine.	 
ALOG(x)	Common (base 10) antilogarithm; 10^x .	
ANGLE(x:y)	Δ polar coordinate for (x,y) rectangular coordinates.†	  
ASIN(x)	Arc sine.†	
ASINH(x)	Hyperbolic arc sine.	 
ATAN(x)	Arc tangent.†	
ATANH(x)	Hyperbolic arc tangent.	 
CDATE	Current date.*	
COMB(x:y)	Number of combinations of x items taken y at a time.	 
COS(x)	Cosine.†	
COSH(x)	Hyperbolic cosine.	 

* Uses the current date format (MM.DDYYYY or DD.MMYYYY). The date format is changed in the TIME SET menu.

† Uses the current angle mode—degrees or radians.















Table 5-3. Solver Functions (Continued)

Function	Description	Typing Aid
CTIME	Current time in H.MMSS, 24-hour format.	
DATE(<i>date</i> : <i>n</i>)	The date <i>n</i> days after (when <i>n</i> is positive) or before (when <i>n</i> is negative) the specified date.*	
DDAYS(<i>d1</i> : <i>d2</i> : <i>cal</i>)	The number of days between dates <i>d1</i> and <i>d2</i> .* <i>cal</i> designates the calendar: <ul style="list-style-type: none"> ■ <i>cal</i> = 1 for the actual calendar, which recognizes leap years. ■ <i>cal</i> = 2 for the 365-day calendar, which ignores leap years. ■ <i>cal</i> = 3 for the 360-day calendar, which uses 12, 30-day months. 	
DEG(<i>x</i>)	Converts <i>x</i> in radians to decimal degrees.	 
EXP(<i>x</i>)	Natural antilogarithm; e^x .	
EXPM1(<i>x</i>)	$e^x - 1$.	
FACT(<i>x</i>)	Factorial; <i>x</i> is an integer ≥ 0 .	 
FP(<i>x</i>)	Fractional part.	 
HMS(<i>x</i>)	Converts <i>x</i> in decimal hours (degrees) to H.MMSS (D.MMSS) format.	 
HRS(<i>x</i>)	Converts <i>x</i> in H.MMSS (D.MMSS) format to decimal format.	 
IDIV(<i>x</i> : <i>y</i>)	Integer part of the quotient of $x \div y$.	

* Uses the current date format (MM.DDYYYY or DD.MMYYYY). The date format is changed in the TIME SET menu.

† Uses the current angle mode—degrees or radians.

Table 5-3. Solver Functions (Continued)

Function	Description	Typing Aid
IF(<i>con</i> : <i>alg1</i> : <i>alg2</i>)	<i>con</i> is a conditional expression, <i>alg1</i> and <i>alg2</i> are algebraic expressions. If <i>con</i> is true, use <i>alg1</i> ; if <i>con</i> is false, use <i>alg2</i> . (See page 103 for additional information.)	
INT(<i>x</i>)	The greatest integer less than or equal to <i>x</i> .	
INV(<i>x</i>)	Reciprocal, $1/x$.	
IP(<i>x</i>)	Integer part.	 
ITEM(<i>listname</i> : <i>x</i>)	Returns value of ITEM(<i>x</i>) in the specified STAT list.	
LN(<i>x</i>)	Natural (base e) log.	
LNP1(<i>x</i>)	$\ln(1 + x)$.	
LOG(<i>x</i>)	Common (base 10) log of <i>x</i> .	
MAX(<i>x</i> : <i>y</i>)	Larger of <i>x</i> and <i>y</i> .	
MIN(<i>x</i> : <i>y</i>)	Smaller of <i>x</i> and <i>y</i> .	
MOD(<i>x</i> : <i>y</i>)	The remainder of the division $x \div y$; $\text{MOD}(x,y) = x - y \times \text{INT}(x \div y)$.	
PERM(<i>x</i> : <i>y</i>)	Permutations of <i>x</i> items taken <i>y</i> at a time.	 
PI	π ; 3.14159265359 (12 digits).	
RAD(<i>x</i>)	Converts <i>x</i> in decimal degrees to radians.	 
RADIUS(<i>x</i> : <i>y</i>)	<i>R</i> polar coordinate for (<i>x</i> , <i>y</i>) rectangular coordinates. [†]	  
RAN#	Pseudo-random number ($0 \leq r < 1$).	 

* Uses the current date format (MM.DDYYYY or DD.MMYYYY). The date format is changed in the TIME SET menu.

† Uses the current angle mode—degrees or radians.

Table 5-3. Solver Functions (Continued)

















Function	Description	Typing Aid
RND($x:y$)	x rounded to y decimal places (when $0 \leq y \leq 11$), or to y significant digits (when $-12 \leq y \leq -1$). y must be an integer.	 
S(var)	var is a variable; used with the IF function to create a menu of variables from more than one equation. (See page 106 for additional information.)	
SGN(x)	Sign of x (+1 if $x > 0$, 0 if $x = 0$, -1 if $x < 0$).	
$\Sigma(cv:c1:c2:s:alg)$	Sums values of the algebraic expression (alg) for values of the counter variable (cv). The counter variable starts with value $c1$ and is incremented in steps of s , to a final value of $c2$. (Refer to page 108 for additional information.)	
SIN(x)	Sine. [†]	
SINH(x)	Hyperbolic sine.	 
SIZES($listname$)	Returns the number of items in the specified STAT list.	
SPFV($i\%:n$)	Future value of a single \$1.00 payment; equivalent to $(1 + i\% \div 100)^n$. n is the number of compounding periods. $i\%$ is the interest rate per compounding period, expressed as a percentage.	
SPPV($i\%:n$)	Present value of a single \$1.00 payment; equivalent to $1 \div SPFV(i\%:n)$. n is the number of compounding periods. $i\%$ is the interest rate per compounding period, expressed as a percentage.	
<p>* Uses the current date format (MM.DDYYYY or DD.MMYYYY). The date format is changed in the TIME SET menu.</p> <p>† Uses the current angle mode—degrees or radians.</p>		

Table 5-3. Solver Functions (Continued)

Function	Description	Typing Aid
SQ(x)	x^2	
SQRT(x)	\sqrt{x}	
TAN(x)	Tangent.†	
TANH(x)	Hyperbolic tangent.	 
TRN(x:y)	x truncated to y decimal places (when $0 \leq y \leq 11$), or to y significant digits (when $-12 \leq y \leq -1$). y must be an integer.	
USFV(i%:n)	Future value of a uniform series of \$1.00 payments; equivalent to $(SPFV(i\%:n) - 1) \div (i\% \div 100)$. n is the number of payments. i% is the periodic interest rate, expressed as a percentage.	
USPV(i%:n)	Present value of a uniform series of \$1.00 payments; equivalent to $USFV(i\%:n) \div SPFV(i\%:n)$. n is the number of payments. i% is the periodic interest rate, expressed as a percentage.	
XCOORD(R:Δ)	x-coordinate of polar coordinates.†	  
YCOORD(R:Δ)	y-coordinate of polar coordinates.†	  

* Uses the current date format (MM.DDYYYY or DD.MMYYYY). The date format is changed in the TIME SET menu.

† Uses the current angle mode—degrees or radians.

Conditional Expressions (IF Function)

Equations can include conditional expressions using the IF function, which has the syntax:

$IF(\text{conditional expression} ; \text{algebraic expression} ; \text{algebraic expression})$

For example, the equation:

$$Y = IF(X > 0 \text{ AND } X < 10 ; 3 \times X^3 - 45 \times X^2 + 350 ; 1000)$$

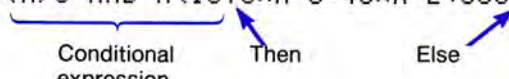

The two colons separate the function into a *conditional expression**, a "Then" *algebraic expression*, and an "Else" *algebraic expression*. The equation states that when the conditional expression is true ($0 < X < 10$), then $Y = 3X^3 - 45X^2 + 350$; otherwise, $Y = 1000$.

Conditional expressions can contain the logical and relational operators described in tables 5-4 and 5-5.

Table 5-4. Operators Used in Conditional Expressions

Logical Operators	Relational Operators	
AND	>	Greater than.
OR	<	Less than.
XOR	=	Equal to.
NOT	> =	Greater than or equal to.
	< =	Less than or equal to.
	< >	Not equal to.

* Conditional expressions containing algebraic expressions may generate the error **INVALID EQUATIONS**. If this happens, insert "+" before the left parenthesis. For example, change $IF((A+2) \div S < 12 ; \dots)$ to $IF(+ (A+2) \div S < 12 ; \dots)$

Table 5-5. Evaluating Logical Expressions

Expression	When A True B True	When A True B False	When A False B True	When A False B False
A AND B	True	False	False	False
A OR B	True	True	True	False
A XOR B	False	True	True	False
NOT A	False	False	True	True
NOT B	False	True	False	True

Here are several additional examples of equations using the IF function:

Equation: $B = \text{IF} (7 < A \text{ AND } A \leq 15 : 2 \times A \div 6 : 3 \times A + 10) + C$

Interpretation: If $7 < A \leq 15$, then $B = 2 \times A \div 6 + C$. Otherwise, $B = 3 \times A + 10 + C$.

Equation: $\text{VALUE} = \text{FIRST} + \text{IF} (\text{NOT FIRST} = 0 : 1 \div \text{FIRST} : 0)$

Interpretation: If $\text{FIRST} \neq 0$, then $\text{VALUE} = \text{FIRST} + (1 \div \text{FIRST})$. If $\text{FIRST} = 0$, then $\text{VALUE} = \text{FIRST}$.

Equation: $T = W \times \text{IF} (A = 0 \text{ XOR } B = 0 : A + B : A \times B)$

Interpretation: $T = W \times (A + B)$ if A or B , but not both, equals 0. Otherwise, $T = W \times A \times B$. In other words:

When $A = 0$ and $B \neq 0$, $T = W \times B$

When $A \neq 0$ and $B = 0$, $T = W \times A$

When $A = 0$ and $B = 0$, $T = 0$

When $A \neq 0$ and $B \neq 0$, $T = W \times A \times B$

Example: Nested IF Functions. An IF function can be used as the argument of another IF function. Placing one IF function within another is called “nesting.”

A corporation uses a rating system to determine salary. Employees are rated on a scale 1 through 3, and are given the following annual percent raise based on their rating:

Rating	Percent Salary Increase
1	3%
2	6%
3	10%

Create a Solver equation that calculates employees’ new salaries based on their previous salary and rating. Then, calculate the new annual salary for an employee with rating 2 who currently earns \$27,500 annually.

1. Press **SOLVE**, then **NEW**.

2. Type:

$NSAL=OSAL \times (1 + IF(R=1; .03; IF(R=2; .06; .1)))$ **INPUT**

3. Press **CALC** to verify the equation and display the menu of variables.

Keys:

Display:

Description:

27500 **OSAL**

OSAL=27,500.0000

Stores the old salary.

2 **R**

R=2.0000

Stores the rating.

NSAL

NSAL=29,150.0000

Calculates the new salary.

Creating Menus for Multiple Equations (S Function)

The S (solving for) function is used with the IF function to group equations and to specify the conditions under which one or the other is used. For example, consider these two equations for converting units:

$$\text{Kilograms} \times 2.205 = \text{Pounds} \quad \text{and} \quad \text{Meters} \times 3.281 = \text{Feet}$$

The equations can be rearranged to place 0 on one side of the equation:

$$\text{Kilograms} \times 2.205 - \text{Pounds} = 0$$

$$\text{Meters} \times 3.281 - \text{Feet} = 0$$

To create one menu that can do either conversion, enter the equation:

Optional: = 0 is implied if omitted

`IF(S(KG) OR S(PND):KG*2.205-PND:M*3.281-FT)=0`

Solving for
either KG
or PND?

If true: use
this expression

If false: use
this expression

The S function appears within the IF function in the conditional expression. In this case, the conditional expression is true if you solve for KG or PND, and false if you solve for anything else. The algebraic expressions in the IF function are the two equations, rewritten to gather all the terms on one side of the equation, so that each expression is equal to 0.*

When you press **CALC**, the HP-27S displays:

1.0000			
KG	PND	M	FT

* The IF function can be set equal to an expression common to both equations. For example, the equations $X+Y+10\div A=Z$ and $Q+R+10\div A=T$ can be combined to

`IF(S(X) OR S(Y) OR S(Z):X+Y-Z:Q+R-T)=-10\div A`. Note that the Solver uses the second equation when solving for Q, R, T, or A.

Example: Unit Conversions. To do kilograms/pounds and meters/feet conversions:

1. Press **SOLVE**, then **NEW**.
2. Type the equation and press **INPUT**.
3. Press **CALC** to verify the equation and display the menu of variables.

Convert 225 pounds to kilograms.

Keys:	Display:	Description:
225 PND	PND=225.0000	Stores number of pounds.
KG	KG=102.0408	Calculates number of kilograms.

How many feet equal 100 meters?

100 M	M=100.0000	Stores number of meters.
FT	FT=328.1000	Calculates number of feet.

The Solver always selects the equation based on the unknown variable. For example, if you store 100 **FT** and then press **PND**, the Solver solves for *PND* using the kilogram/pound equation and the current value stored in *KG*.

The Summing (Σ) Function

The Σ function provides the ability to do a variety of summing operations. The syntax of the function is:

Σ (*counter variable* ; *starting value* ; *ending value* ; *step size* ; *algebraic expression*)

The *counter variable* takes on a series of values, beginning with the *starting value*, and incrementing according to the *step size*, until it passes the *ending value*. For each value of the counter, the *algebraic expression* is evaluated, and the value is added to the previous value. The function returns the final summation.

For example, when the the equation:

$$\text{SERIES} = \Sigma(I : 1 : 6 : 1 : I \times X^I)$$

is solved for *SERIES*, it uses the stored value of *X* to calculate $X + 2X^2 + 3X^3 + 4X^4 + 5X^5 + 6X^6$. The counter *I* runs from 1 through 6 in steps of 1—that is, 1, 2, 3, 4, 5, 6. For each value *I*, the expression $I \times X^I$ is calculated and added to the sum. The counter variable does not appear in the menu of variables.

The following equation uses a variable as the ending value, 0 as the beginning value, and a step size of 2.

$$\text{SERIES} = \Sigma(I : 0 : \text{LAST} : 2 : I \times X^I)$$

If 8 is stored in *LAST*, *I* takes on values of 0, 2, 4, 6, and 8. Solving for *SERIES* in this equation calculates $2X^2 + 4X^4 + 6X^6 + 8X^8$.

Example: A Series Expansion. $\sin x$ can be calculated by the series:

$$\sin x = \sum_{i=0}^{\infty} \frac{(-1)^i x^{2i+1}}{(2i+1)!}$$

1. To enter the equation, press **SOLVE**, then **NEW**.
2. Type*:

SINX=Σ(I:0:LAST:1:(-1)^I×X^(2×I+1)÷
FACT(2×I+1)) **INPUT**.

3. Press **CALC** to verify the equation and display the menu of variables.

Calculate the sine of $\pi/2$ radians:

Keys:	Display:	Description:
10 LAST	LAST=10.0000	Store ending value for I.
π ÷ 2 X	X=1.5708	Stores angle in radians.
SINX	S=1.0000	Calculates sine.

* To type Σ , press **ABCDE** **OTHER**, **MORE** **Σ**.

Summing Operations With STAT Lists

The Σ function can be used to perform summing operations on data stored in STAT lists. Two Solver functions allow you to access that data.

- **SIZES**(*list name*) returns the number of items in the specified list.
- **ITEM**(*list name* : *item number*) returns the value of the specified item.

For example, the following equation calculates $\sum x_i^2 y_i^2$ for two lists named XVAR and YVAR that have the same number of items:

$$\text{SX2Y2} = \Sigma(\text{I}; 1 : \text{SIZES}(\text{XVAR}); 1 : \text{ITEM}(\text{XVAR}; \text{I})^2 \times \text{ITEM}(\text{YVAR}; \text{I})^2)$$

“Calculating Subtotals” on page 186 illustrates another application of the Σ function with STAT lists.

How the Solver Works

Direct and Iterative Solutions

When you start a calculation, the Solver attempts to find a *direct* solution by algebraically rearranging the equation to isolate the unknown. If a direct solution is found, the HP-27S displays the answer with no other information. For example, to solve:

$$\text{DISTANCE} = V_0 \times \text{TIME} - .5 \times G \times \text{TIME}^2$$

for V_0 , the Solver internally rearranges the equation to isolate V_0 :

$$V_0 = (\text{DISTANCE} + .5 \times G \times \text{TIME}^2) \div \text{TIME}$$

If the Solver cannot isolate the unknown, it uses an *iterative* (repetitive) process to search for a solution that sets the left side of the equation equal to the right side. The Solver starts with two initial estimates of the answer—your guesses, or numbers it generates. Using one of the estimates, the Solver evaluates the left and right sides of the equation (*LEFT* and *RIGHT*) and calculates *LEFT* minus *RIGHT* (*LEFT*–*RIGHT*). Then, the Solver repeats the calculation for the other estimate. If neither estimate produces a value of 0 for *LEFT*–*RIGHT*, the Solver produces two new estimates that appear to be closer to the answer. By repeating this process many times, the Solver approaches the answer.

During the iterative search, the HP-27S displays the two current estimates and the sign of *LEFT*–*RIGHT* for each estimate.*

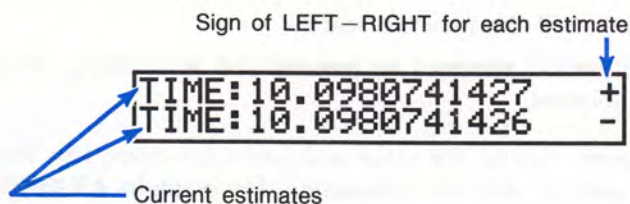

Halting and Restarting an Iterative Search

The iterative search can take several minutes. You can halt the search by pressing any key except \blacksquare . Then, press \blacktriangleleft or CLR to see the best estimate the Solver has found. To restart the search from where it left off, press the menu key for the unknown.

If the estimates don't seem to be proceeding towards a number you judge to be a reasonable answer, you can halt the search, enter your own guesses, and restart the search.

* A question mark beside an estimate indicates that *LEFT*–*RIGHT* cannot be calculated for that estimate.

Entering Guesses

Entering guesses gives you control over the initial estimates used in an iterative search. Since the search starts in the range between the two initial estimates, entering guesses can reduce the number of iterations required to find a solution. Also, if more than one solution exists, guesses can help select the desired answer. The closer your guesses are to the desired solution, the better chance the Solver has of finding it.

You can enter one or two guesses at these times:

- Before beginning the calculation, after you've stored a value for every variable except the unknown. If you enter one guess, the Solver generates a second estimate.
- After you've halted the iterative search.
- After the Solver has returned an answer, and you wish to search for another solution.

To enter one guess, key in the value and press the menu key. Press the menu key again to start the calculation. For example, 4.5 **⏏** **⏏** starts the calculation with the guess $A = 4.5$.

To enter two guesses, key in the first guess and press the menu key. Key in the second guess and press the menu key again. To start the calculation, press the menu key a third time. For example 0 **⏏** **⏏** **⏏** starts the search for A in the range 0 through 100.

Example: Entering Guesses. Use the equation of motion for free fall from the example on page 89 to calculate how long it takes an object to fall 1,000 meters. Use 10 and 15 as guesses.

If you have not already entered the equation, follow steps 1 through 3 on page 89, and store 9.8067 in G and 0 in $V0$. Then:

Keys:	Display:	Description:
1000 $\boxed{+/-}$ \boxed{DISTR}	DISTANCE= -1,000.0000	Stores the <i>DISTANCE</i> .
10 \boxed{TIME} 15 \boxed{TIME}	TIME=15.0000	Enters the guesses.
\boxed{TIME}	TIME=14.2808	Iterative solution for <i>TIME</i> .

Outcomes of an Iterative Solution

Cases 1, 2, 3, and 4 describe the possible outcomes of an iterative solution. See appendix B for examples of the four cases.

Case 1: The HP-27S displays an answer on the calculator line. It is *very* likely that the solver has found a solution.

There are two situations in which the Solver returns a case 1 answer (see figure 5-1).

- **Case 1a:** *LEFT* - *RIGHT* is exactly 0.
- **Case 1b:** *LEFT* - *RIGHT* is not zero for either estimate. However, the two final estimates are *neighbors*—they are as close together as possible, given the calculator's 12-digit precision. *LEFT* - *RIGHT* is positive for one estimate, and negative for the other estimate.

LEFT-RIGHT

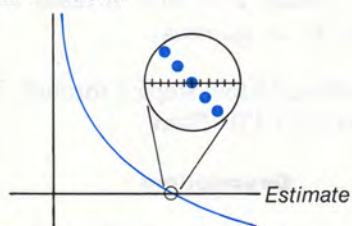

Case 1a:

LEFT-RIGHT

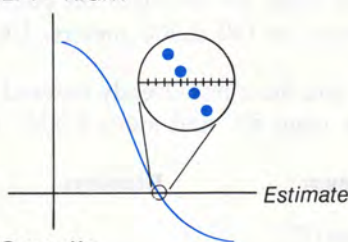

Case 1b:

Figure 5-1. Iterative Solutions—Case 1

At the conclusion of the calculation, you can determine whether the solution is case 1a or 1b by pressing the menu key for the unknown. If *LEFT-RIGHT* is *not* exactly 0, the HP-27S displays *LEFT* and *RIGHT* for the answer. Pressing or redisplay the answer.

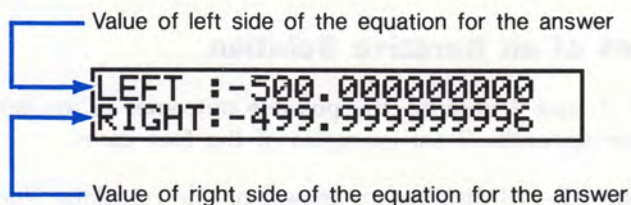

The equation could have more than one solution. If the answer does not seem reasonable, enter one or two guesses and recalculate the answer.

Case 2: The HP-27S beeps and displays the values of *LEFT* and *RIGHT* for the answer. The Solver has found a *possible* solution, but *you must use judgement* in interpreting the results. To view the answer, press or . If the answer seems unreasonable, it could be because the equation has more than one solution. You might want to enter one or two initial estimates and restart the search.

There are three comparisons to help you interpret a case 2 solution:

- Whether the values of *LEFT* and *RIGHT* are relatively far apart or close together.
- Whether *LEFT*–*RIGHT* for the two final estimates have the same or opposite signs.
- Whether the two final estimates are relatively far apart or close together; in particular, whether they are neighbors.

To view the two final estimates, press and hold down the menu key for the unknown until the numbers stop changing. As long as you hold down the key, the HP-27S displays the last estimates and the signs of *LEFT*–*RIGHT* for each estimate.

There are three situations in which the Solver returns a case 2 solution: (see figure 5-2):

- **Case 2a:** The signs of *LEFT*–*RIGHT* are opposite and the two estimates are neighbors. The Solver found two estimates that bracket an ideal solution (a solution where *LEFT*–*RIGHT* equals 0). The answer may possibly be a solution. It is more likely that the answer is a solution if *LEFT* and *RIGHT* are relatively close together than if they are relatively far apart.
- **Case 2b:** The signs of *LEFT*–*RIGHT* are opposite and the two estimates are not neighbors. You should be very cautious about accepting the answer as a solution. However, if *LEFT* and *RIGHT* are relatively close together, the answer may be a solution.
- **Case 2c:** *LEFT*–*RIGHT* for the two estimates have the same sign. The Solver halted because it could find no estimates that further reduced the magnitude of *LEFT*–*RIGHT*. You should reject the answer unless the values of *LEFT* and *RIGHT* are relatively close together. If *LEFT* and *RIGHT* are relatively close together, the answer may possibly be a solution.

LEFT-RIGHT

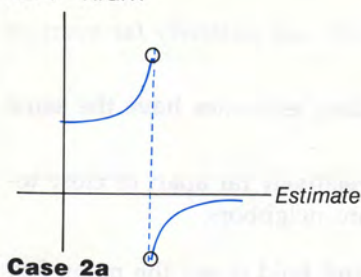

LEFT-RIGHT

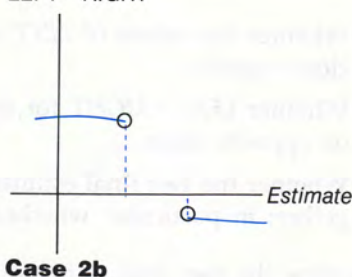

LEFT-RIGHT

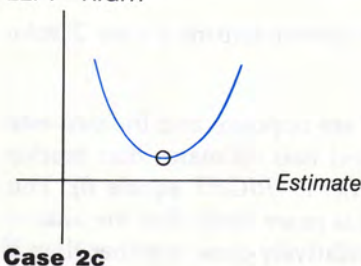

Figure 5-2. Iterative Solutions—Case 2

Case 3: The HP-27S displays:

BAD GUESSES:
PRESS [CLR] TO VIEW

The Solver cannot begin the search with the initial estimates. Pressing [CLR] or \blacktriangledown displays the two initial estimates. Pressing any other key except \blacksquare restores the calculator line and menu of variables. There may be a solution you can find by entering good guesses (see "Entering Guesses" on page 112).

Case 4: The HP-27S beeps and displays SOLUTION NOT FOUND. The Solver is unable to make progress towards a solution. Make sure the equation has been entered correctly. Also check the values of the known variables. If the equation and variables are correct, you *may* be able to find a solution by entering very good guesses.

6

Time Value of Money

The TVM application does *time value of money* calculations, which are based on money earning *compound interest* over a period of time. Compound interest calculations take into account that interest, added to the principal at specified compounding periods, also earns interest. Loans, savings accounts, pension funds, and leases are examples of time value of money calculations.

Specifically, the TVM application does calculations based on a series of *cash flows* (money received or money paid) where:

- The dollar amount is the same for each payment.
- The payments occur at regular intervals.
- The payment periods coincide with the compounding periods.

The TVM application also does amortization calculations, which determine the amounts applied toward principal and interest in a payment or series of payments.

Entering the TVM Application

To enter the TVM application, press **[TVM]**. The HP-27S displays the top-level TVM menu and a message describing the current payment conditions.

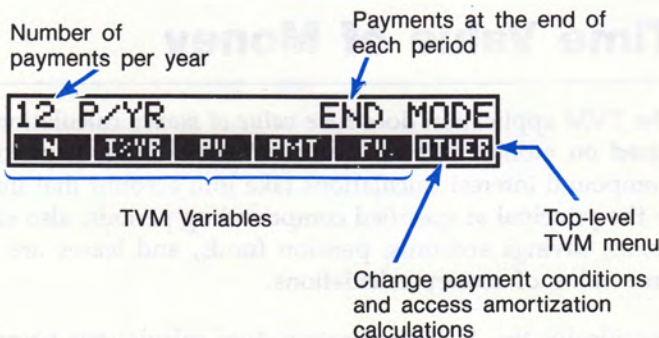

The **OTHER** key displays the second-level menu, which is used to change the payment conditions and to access the amortization (AMRT) menu.

Table 6-1 describes the top-level and second-level menus.

Table 6-1. TVM Menu Keys

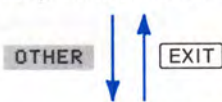
Menu Key	Description
Top Level	
N	Stores or calculates the <i>total</i> number of payments or compounding periods.* <i>N</i> can be expressed in any unit of time—for example, years, months, or days.
I%YR	Stores or calculates the nominal <i>annual</i> interest rate as a percentage.
PV	Stores or calculates the present value—an initial cash flow or a discounted value of a series of future cash flows (<i>PMTs</i> + <i>FV</i>). To a lender or borrower, <i>PV</i> is the amount of the loan; to an investor, <i>PV</i> is the initial investment. <i>PV</i> always occurs at the beginning of the first period.
PMT	Stores or calculates the dollar amount of each periodic payment. All payments are equal, and no payments are skipped. Payments can occur at the beginning or end of each period.
FV	Stores or calculates the future value—a final cash flow or a compounded value of a series of previous cash flows (<i>PV</i> + <i>PMTs</i>). <i>FV</i> always occurs at the end of the last period.
	
Second Level	
P/YR	Stores the number of payments per year or compounding periods per year. The value must be an integer in the range 1 through 999.
BEG	Sets <i>Begin mode</i> ; payments occur at the beginning of each period.
END	Sets <i>End mode</i> ; payments occur at the end of each period.
AMRT	Displays the AMRT (amortization) menu for calculating amortization schedules.
<p>* When the calculator calculates a non-integer <i>N</i>, the answer must be interpreted carefully. Interpreting a non-integer <i>N</i> is shown in the savings account example on page 127.</p> <p>Calculations using a stored non-integer <i>N</i> produce a mathematically correct result, but this result has no simple, useful interpretation.</p>	

Cash-Flow Diagrams and Sign Convention

It is helpful to illustrate TVM calculations with *cash-flow diagrams*. Cash-flow diagrams are time lines divided into equal segments of time representing *compounding* (or *payment*) *periods*. Arrows show the cash flows. Money received is a positive number; money paid out is a negative number. The directions of the arrows for a transaction depend on the point of view taken in the problem. For example, a loan is an initial *positive* cash flow to the borrower and a *negative* cash flow for the lender (see figures 6-1 and 6-2).

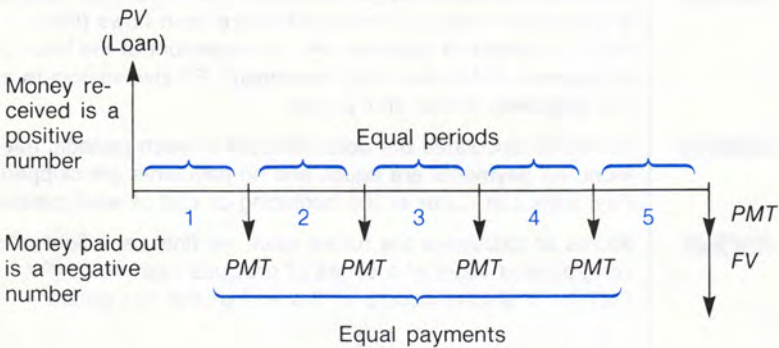

Figure 6-1. Loan From Borrower's Point of View

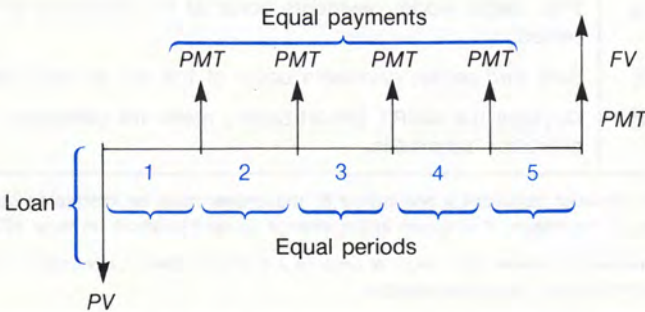

Figure 6-2. Loan From Lender's Point of View

Figures 6-3 and 6-4 illustrate payments occurring at the *beginning* and *end* of each period.

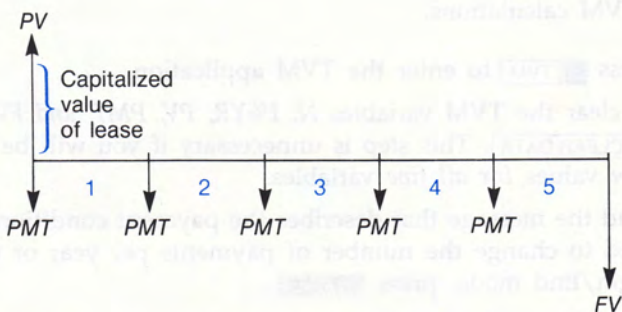

Figure 6-3. Lease Payments at Beginning of Each Period

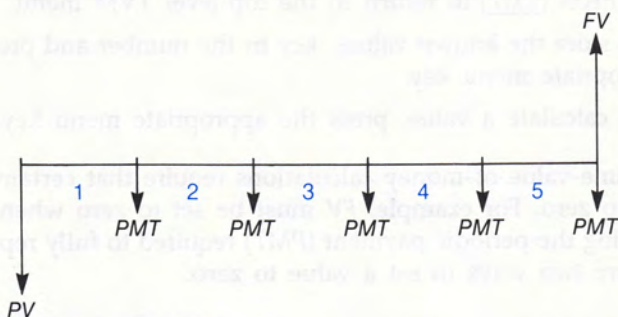

Figure 6-4. Deposits Into an Account at End of Each Period

TVM Calculations

To do TVM calculations:

1. Press **[TVM]** to enter the TVM application.
2. To clear the TVM variables N , $I\%YR$, PV , PMT , and FV , press **[CLEAR DATA]**. This step is unnecessary if you will be entering new values for *all five* variables.
3. Read the message that describes the payment conditions. If you need to change the number of payments per year or the Begin/End mode, press **[OTHER]**.
 - To change the number of payments per year, key in the new value and press **[P/YR]**.
 - To change the Begin/End mode, press **[BEG]** or **[END]**.
 - Press **[EXIT]** to return to the top-level TVM menu.
4. To store the known values, key in the number and press the appropriate menu key.
5. To calculate a value, press the appropriate menu key.

Some time-value-of-money calculations require that certain variables be set to zero. For example, FV must be set to zero when you are calculating the periodic payment (PMT) required to fully repay a loan. There are two ways to set a value to zero:

- Before storing any TVM values, press **[CLEAR DATA]** to clear the TVM variables (step 2, above).
- Store zero; for example, pressing 0 **[FV]** sets FV to zero.

Clearing the TVM Variables

The calculator retains the values stored in the TVM variables until you clear them by pressing **[CLEAR DATA]**. When the HP-27S is displaying the top-level TVM menu, pressing **[CLEAR DATA]** clears N , $I\%YR$, PV , PMT , and FV . When the second-level menu is displayed, pressing **[CLEAR DATA]** sets the payment conditions to
12 P/YR END MODE.

Loan Calculations

The following examples illustrate common loan calculations. Loan calculations typically use End mode. For amortization of loan payments, see page 130.

Example: A Car Loan. You are financing the purchase of a car with a 3-year loan at 10.5% annual interest, compounded monthly. The purchase price of the car is \$7,250. Your down payment is \$1,500. What are your monthly payments? (Assume payments start one month after purchase—in other words, at the *end* of the first period.) Also, what interest rate would reduce your monthly payment by \$10?

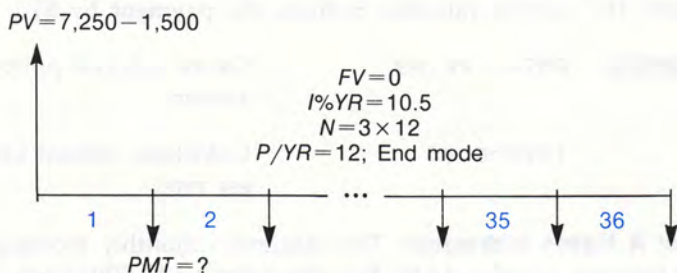

Keys:

TVM

MODES

FIX

2 INPUT

CLEAR DATA

OTHER

CLEAR DATA

EXIT

Display:

12 P/YR END MODE

Description:

Enters TVM application.

Sets display to two decimal places.

Optional; clears TVM variables.

If necessary; sets 12 payment periods per year; End mode.

3 \times 12

N

N=36.00

Stores number of payments.

10.5 I%YR

I%YR=10.50

Stores annual interest rate.

7250 \square 1500

PV

PV=5,750.00

Stores the loan amount.

0 FV

FV=0.00

Sets FV to 0; not necessary if you previously cleared the variables.

PMT

PMT=-186.89

Calculates the payment—money *paid out*.

To calculate the interest rate that reduces the payment by \$10:

+ 10

PMT

PMT=-176.89

Stores reduced payment amount.

I%YR

I%YR=6.75

Calculates annual interest rate.

Example: A Home Mortgage. The maximum monthly mortgage payment you can afford is \$630. You can make a \$12,000 down payment, and annual interest rates are currently 11.5%. If you take out a 30-year mortgage, what is the maximum purchase price you can afford?

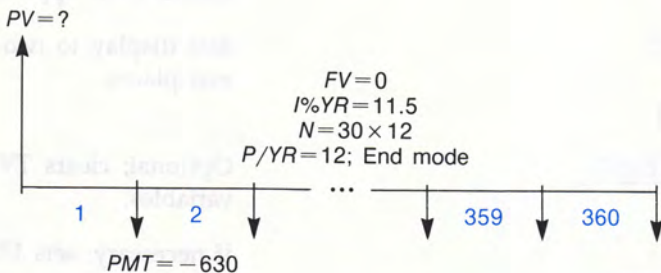

Keys:**Display:****Description:**

TVM

Enters the TVM application.

MODES

FIX

2 **INPUT**

Sets display to two decimal places.

CLEAR DATA

Optional; clears TVM variables.

OTHER

CLEAR DATA

EXIT

12 P/YR END MODE

If necessary: sets 12 payment periods per year; End mode.

30 **x** 12

N

N=360.00

Stores number of payments.

11.5 **I%YR**

I%YR=11.50

Stores annual interest rate.

630 **+/-**

PMT

PMT=-630.00

Stores monthly payment.

0 **FV**

FV=0.00

Sets FV to 0; not necessary if you previously cleared TVM variables.

PV

PV=63,617.64

Calculates loan amount.

+ 12000 **=**

75,617.64

Calculates total price of the house (loan plus down payment).

Example: A Mortgage With a Balloon Payment. You've taken out a 25-year, \$75,250 mortgage at 13.8% annual interest. You anticipate that you will own the house for four years and then sell it, repaying the loan in a "balloon payment." What will be the size of your balloon payment at the end of four years?

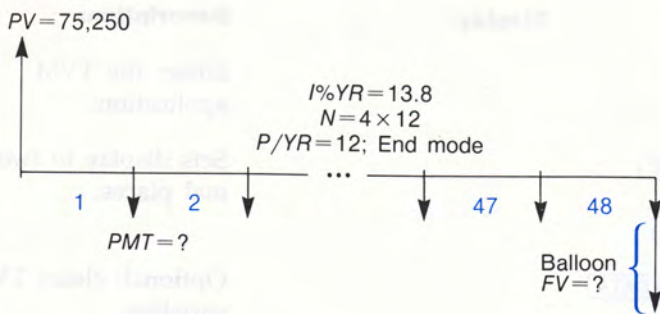

The problem is done in two steps:

1. Calculate the monthly payment to repay the loan in 25 years.
2. Calculate the balloon payment after 4 years.

Keys:

Display:

Description:

TVM

Enter the TVM application.

MODES

Sets display to two decimal places.

FIX

2 INPUT

CLEAR DATA

Optional; clears TVM variables.

OTHER

CLEAR DATA

If necessary: sets 12 payment periods per year; End mode.

EXIT

12 P/YR END MODE

Step 1. Calculate PMT for the mortgage:

25 **x** 12

Stores total number of payments.

N

$N=300.00$

13.8

I%YR

$I\%YR=13.80$

Stores annual interest rate.

75250

PV

$PV=75,250.00$

Stores loan amount.

0 **FV** FV=0.00

Sets *FV* to 0; not necessary if you previously cleared the variables.

PMT PMT=-894.33

Calculates monthly payment.

Step 2. Calculate the balloon payment after 4 years:

PARTS

Rounds displayed number internally to two decimal places.*

RND

EXIT -894.33

PMT

PMT=-894.33

Stores rounded value.

4 **X** 12

Stores number of payments in 4 years.

N

N=48.00

FV

FV=-73,408.81

Calculates balloon payment.

The balloon plus the last monthly payment fully repays the loan:

+ **RCL**

Amount to repay loan.

PMT

=

-74,303.14

Savings Calculations

Example: A Savings Account. You deposit \$2,000 into a savings account that pays 7.2% annual interest, compounded annually. If you make no other deposits, how long will it take for the account to contain \$3,000? (Since $PMT=0$, the Begin/End mode is irrelevant.)

* *PMT* calculated in the previous step is stored as the 12-digit number -894.330557971. The calculation of the balloon payment should use the actual monthly payment amount (dollars and cents), the rounded number \$894.33.

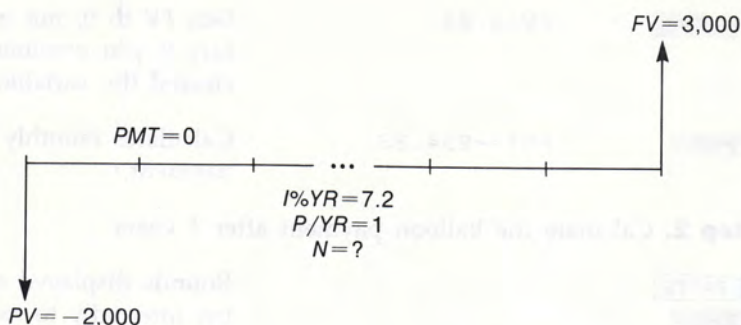

Keys:

Display:

Description

TVM

Enters the TVM application.

MODES

Sets display to two decimal places.

FIX

2 INPUT

CLEAR DATA

Optional; clears TVM variables.

OTHER

1 P/YR

Sets 1 compounding period per year.

EXIT

1 P/YR

7.2 I%YR

I%YR=7.20

Stores annual interest rate.

2000 +/- PV

PV=-2,000.00

Stores amount of the deposit.

0 PMT

PMT=0.00

There are no payments; not necessary if you previously cleared TVM variables.

3000 FV

FV=3,000.00

Stores future account balance.

N

N=5.83

Calculates number of years.

Since the calculated value of N is between 5 and 6, it will take 6 years of annual compounding to achieve a balance of at least \$3,000. The actual balance at the end of six years can be calculated:

6	N	$N=6.00$	Stores N for six years.
	FV	$FV=3,035.28$	Calculates balance after six years.

Example: An Individual Retirement Account. You opened an individual retirement account on April 15, 1985 with a deposit of \$2,000. Thereafter, you deposit \$80.00 into the account semimonthly at the end of each half-month. The account pays 8.3% annual interest, compounded semimonthly. How much will the account contain on April 15th, 2000?

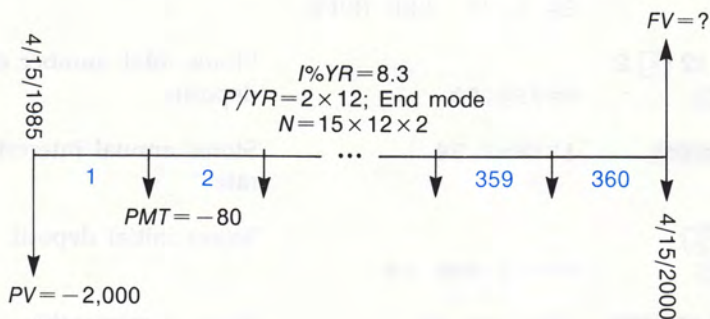

Keys:	Display:	Description:
TVM		Enters the TVM application.
MODES		Sets display to two decimal places.
FIX		
2 INPUT		
CLEAR DATA	0.00	Optional; clears TVM variables.
OTHER 2		Sets payment conditions.
12		
P/YR		
END		
EXIT	24 P/YR END MODE	
15 12		Stores total number of deposits.
N	N=360.00	
8.3 I%YR	I%YR=8.30	Stores annual interest rate.
2000 +/-		Stores initial deposit.
PV	PV=-2,000.00	
80 +/- PMT	PMT=-80.00	Stores semimonthly payment.
FV	FV=63,963.84	Calculates balance after 15 years.

Amortization

The AMRT menu displays or prints the following values for a single loan payment or a series of loan payments:

- The balance of the loan after the payment(s) are made.
- The amount of the payment(s) applied toward interest.
- The amount of the payment(s) applied toward principal.

Table 6-2. The AMRT Menu

Menu Key	Description
For displaying an amortization schedule:	
#P	Stores the number of payments to be amortized, and calculates an amortization schedule for that many payments. #P must be an integer in the range 1 through 1,200.
INT	Displays the amount of the payments applied toward interest.
PRIN	Displays the amount of the payments applied toward principal.
BAL	Displays the balance of the loan after the payments have been made.
NEXT	Calculates the amortization schedule for the next set of payments, using the stored value of #P.
For printing an amortization schedule:	
TABLE	Displays a menu for printing an amortization schedule.

Displaying an Amortization Schedule

The following steps display an amortization schedule. (See page 134 for printing an amortization schedule). If you've just completed the TVM calculation for the loan, skip steps 1 through 3.

1. Set the display format to the desired number of decimal places. Amortization calculations use values of *PV*, *PMT*, and *INT* rounded to the number of decimal places specified by the current display setting. (This does not affect the stored values of *PV* and *PMT*.)
2. Press **TVM** to enter the TVM application.
3. Store the values for *I%YR*, *PV*, and *PMT*. If you need to calculate one of these values, follow the instructions for doing TVM calculations on page 122.
4. Press **OTHER** to display the second-level TVM menu.
5. If necessary, change the number of payment periods per year by keying in the value and pressing **P/YR**.

6. If necessary, change the payment mode by pressing **BEG** or **END**.
7. Press **AMRT**.
8. Key in the number of payments to be amortized and press **#P**. The HP-27S displays a message indicating the payments that have been amortized, and the history stack is filled with the calculation results.
9. To display the calculation results:
 - You can press **▼** repeatedly to roll the history stack.
 - You can display one or more particular values by pressing **INT**, **PRIN**, and/or **BAL**.
10. To continue displaying the schedule for subsequent payments, do one of the following:
 - Key in the number of succeeding payments to be amortized and press **#P**.
 - Press **NEXT** to use the previously stored value for **#P**.

To start the amortization schedule over from payment #1, press **CLEAR DATA** and proceed from step 8.

Example: Displaying an Amortization Schedule. To purchase your home, you have taken out a 30-year, \$65,000 mortgage at 12.5% annual interest. Your monthly payment is \$693.72. Calculate the amount of the first year's and second year's payments that are applied toward principal and interest. Then, calculate the loan balance after making payments for 3½ years.

Keys:	Display:	Description:
MODES		Sets amortization rounding to dollars and cents.
FIX		
2 INPUT		
TVM		Enters TVM application.
12.5 I%YR	I%YR=12.50	Stores annual interest rate.
65000 PV	PV=65,000.00	Stores loan amount.

693.72 Stores monthly payment.
 PMT=-693.72

Sets payment conditions.
 12 P/YR END MODE

KEY #PMTS; PRESS Displays AMRT menu.
 <#P>

12 #P=12 PMTS: 1-12 Calculates amortization
 schedule for payments
 1-12.

INTEREST=-8,113.16 Displays results by roll-
 PRINCIPAL=-211.48 ing the history stack.
 BALANCE=64,788.52

#P=12 PMTS: 13-24 Calculates amortization
 schedule for next 12
 payments.

INTEREST=-8,085.15 Displays results using the
 PRINCIPAL=-239.49 menu keys.
 BALANCE=64,549.03

To display the balance after 3½ years (42 payments), amortize 18 ad-
 ditional payments (42 - 24 = 18):

18 #P=18 PMTS: 25-42 Calculates amortization
 schedule for the next 18
 months.

BALANCE=64,129.05 Displays balance.

Printing an Amortization Schedule

To print an amortization schedule using the optional Infrared Printer, do steps 1 through 7 for displaying an amortization schedule (see page 131). Then, proceed to step 8 below (ignore the message KEY #PMTS; PRESS {#P}):

8. Press **TABLE**.
9. Key in the payment number of the first payment in the schedule and press **FIRST**.
10. Key in the payment number of the last payment in the schedule and press **LAST**.
11. Key in the increment—the number of payments per table entry—and press **INCR**.
12. Press **GO**.

The values set in the TABLE menu are retained until you exit the TABLE menu.

Example: Printing an Amortization Schedule. For the loan described in the example on page 132, print an amortization schedule with entries for the fifth and sixth years.

Use the same keystrokes up to and including pressing **AMRT**. Then:

Keys:	Display:	Description:
TABLE		Displays TABLE menu.
4 (x) 12 (+) 1 FIRST	FIRST=49.00	Starts table from 49th payment.
6 (x) 12 LAST	LAST=72.00	The 72nd payment is the last one in year six.

12 INCR

INCR=12.00

Each table entry represents 12 payments.

60

Calculates and prints the amortization schedule shown below.

I%YR=	12.50
PV=	65,000.00
PMT=	-693.72
P/YR=	12.00
END MODE	
PMTS: 49-60	
INTEREST=	-7,976.87
PRINCIPAL=	-347.77
BALANCE=	63,622.94
PMTS: 61-72	
INTEREST=	-7,930.82
PRINCIPAL=	-393.82
BALANCE=	63,229.12

7

Time, Appointments, and Date Arithmetic

The calculator contains a clock and calendar, which are used by the TIME application. You can select a 12-hour or 24-hour clock, and an American (month/day/year) or European (day.month.year) calendar format. You can also:

- Store appointments that set alarms with optional messages.
- Determine the day of the week for a particular date.
- Calculate the number of days between two dates, using the 360-day, the 365-day, or the actual calendar.

Viewing the Time and Date

To view the day of the week, date, and time, press **TIME** to enter the TIME application.

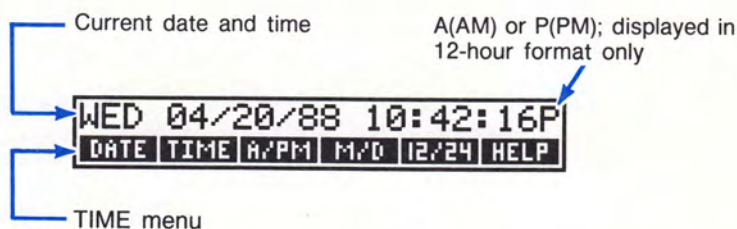

If you overwrite the time and date, you can restore them to the display by pressing **CLR**.

Table 7-1 describes the TIME menu:

Table 7-1. The TIME Menu

Menu Key	Description
CALC	Displays the CALC menu, which is used for date arithmetic, and to determine the day of the week for any date.
APPT	Displays the APPT menu for setting and viewing appointments.
ADJST	Displays the ADJST menu for adjusting the clock setting.
SET	Displays the SET menu for setting the time and date; also selects the time and date formats.

Setting the Time and Date

Table 7-2 describes the SET menu, which is used to set the time and date and to change the time and date formats.

To set the time:

1. Enter the TIME application (press **TIME**) and press **SET** to display the SET menu. Note the current time format—A or P after the time indicates 12-hour format.
2. Using the current format, key in the correct time* as a number in the form HH.MMSS. For example 9:08:30 p.m. would be keyed in as 9.0830 (12-hour format) or 21.0830 (24-hour format).
3. Press **TIME** to set the clock.
4. For 12-hour format only: If necessary, press **A/PM** to switch between AM and PM.

* To set the exact time from a time standard, key in an HH.MMSS value 15 to 30 seconds in the future. Press **TIME** when the two times match.

To set the date:

1. Note the current date format. If the date contains slashes (for example, 10/23/89), the current format is month/day/year. If the date contains periods (for example, 23.10.89), the current format is day.month.year.
2. Key in the correct date as a seven- or eight-digit number, using the current format. For example, April 3, 1989 would be 4.031989 (MM.DDYYYY) in month/day/year format or 3.041989 (DD.MMYYYY) in day.month.year format.
3. Press **DATE** .

Table 7-2. The SET Menu

Menu Key	Description
DATE	Enters the number in the calculator line as the current date.
TIME	Enters the number in the calculator line as the current time.
A/PM	In 12-hour format, switches between AM and PM.
M/D	Switches between month/day/year and day.month.year formats.
12/24	Switches between 12-hour and 24-hour formats.
HELP	Displays the keystrokes for keying in the date and time.

Example: Setting the Date and Time. Set the date and time to June 9, 1988, 4:07 p.m.

Keys:	Displays:	Description:
TIME		Displays the current settings.
SET		Displays the SET menu.
6.091988		Sets the date.
DATE	THU 06/09/88	
4.07 TIME		
A/PM *	THU 06/09/88 04:07:xxP	Sets the time.

Changing the Time and Date Formats

Use the SET menu to change the time and date formats (press **TIME**, then **SET**). To switch between the 12- and 24-hour time format, press **12/24**. To switch between month/day/year and day.month.year format, press **M/D**.

Adjusting the Clock Setting

The ADJST menu adjusts the time setting forward or backward in increments of hours, minutes, or seconds.

To adjust the time setting, from the TIME menu:

1. Press **ADJST**.
2. Press the appropriate menu key(s) until the correct time is displayed. For example, if the current time setting is 11:20:xx AM (ignoring seconds), pressing **+HR** twice changes the time to 1:20 PM. Then, pressing **-MIN** three times changes the time to 1:17 PM.

* Press if necessary to switch to P (p.m.).

Appointments

The HP-27S has 10 appointments. Each can contain an optional message. You can also designate repeating appointments—ones that go off at regular intervals.

Viewing and Setting an Appointment

To set an appointment or view its current setting:

1. Press **TIME**, then **APPT**. The bottom line contains menu labels for the first five appointments. If any of those appointments are "set" to some time in the future, or are past "due" because they went off without being acknowledged, the top line describes their status.

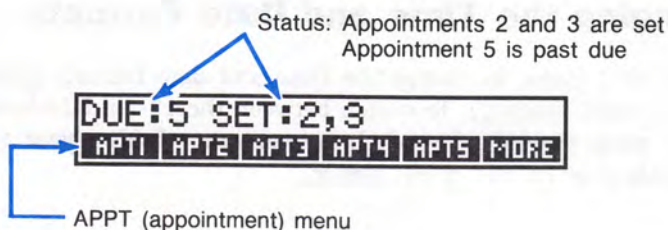

Pressing **MORE** displays the rest of the APPT menu and the status of appointments 6 through 10.

2. Press a menu key—**APT1** through **APT10**. The display shows the date and time for that appointment and the menu for setting appointments described in table 7-2.

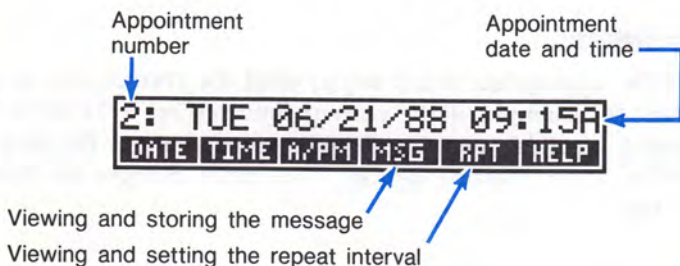

Table 7-2. The Appointment-Setting Menu

Menu Key	Description
DATE	Enters the number on the calculator line as the appointment date.
TIME	Enters the number on the calculator line as the appointment time.
A/PM	In 12-hour time mode, sets AM or PM.
MSG	Displays the current message or ALPHA menu for typing a message.
RPT	Displays the current repeat interval and the menu for changing the repeat interval.
HELP	Displays the keystrokes for setting the appointment time and date.

CLR restores the appointment time and date to the display if it has been overwritten by calculator line operations.

- Optional: Press **CLR** **CLEAR DATA** to clear the appointment.
- If you are uncertain how to key in the time or date, press **HELP**.
- Setting the appointment time:** Note the time format in use—A or P after the time indicates 12-hour format. Key in the time of the appointment in HH.MM format. For example, 2:25 p.m. would be 2.25 (12-hour format) or 14.25 (24-hour format). Press **TIME**. If the date setting was a date in the past (including 00/00/0000), the date is automatically set to the current date. For 12-hour format only: If necessary, press **A/PM** to switch between AM and PM.
- Setting the appointment date:** Key in the appointment date as a number, using the current date format. For example, October 4, 1988 would be 10.041988 (month/day/year format) or 4.101988 (day.month.year format). Press **DATE**. If you omit the year, the calculator assumes the appointment is within the next year.

7. **The appointment message:** Press **MSG** to store a message or to view or edit the current message. Type the message (if necessary, see page 36 for information about the ALPHA and ALPHA-edit menus). Messages can have a maximum of 22 characters. Press **INPUT** to store the new message, or **EXIT** to retain the original message (the one that was displayed when you pressed **MSG**).
8. **The repeat interval:** Press **RPT** to display the current repeat interval and the RPT menu.



To set or change the repeat interval, key in an integer and press the appropriate key. For example, 2 **DAY** causes the appointment to go off at the same time every other day; 90 **MIN** sets the repeat interval to 1½ hours. **NONE** sets the appointment to non-repeating. You can specify repeat intervals up to 104 weeks in length (728 days, 17,472 hours, etc.)

9. Press **EXIT** to return to the APPT menu. The appointment you just set will be listed as set.

Acknowledging an Appointment

When an appointment “comes due,” the HP-27S beeps and the appointment annunciator comes on.* If the appointment has a message, it is displayed; otherwise, the HP-27S displays the date and time. If the calculator is turned off, it turns itself on to announce the appointment.

* If the HP-27S is in the middle of a complex calculation when an appointment comes due, the appointment annunciator comes on and the calculator beeps once. When the calculation is done, the HP-27S displays the message and resumes beeping for 20 seconds.

The beeper does not sound in BEEPER OFF mode.

To acknowledge the appointment and clear the message, press any key except **■** while the calculator is beeping. Appointments not acknowledged within 20 seconds become past due.

Unacknowledged Appointments

If an appointment is not acknowledged within 20 seconds, the beeping stops and the appointment becomes past due (unacknowledged). The appointment annunciator ((●)) remains on to inform you of the past due appointment.

To acknowledge a past due appointment:

1. Press **■** **TIME**, then **■** **APPT**. Press **■** **MORE**, if necessary, to see the status of appointments 6 through 10.
2. Press the menu key for the past due appointment. You can view the message by pressing **■** **MSG**.
3. Press **■** **EXIT** to return to the APPT menu. The acknowledged appointment is no longer listed as past due.

A repeating appointment is deactivated while it is past due. It will not go off at subsequent repeat intervals until the appointment is acknowledged.

Clearing Appointments

Clearing an appointment changes the date and time to 00/00/0000, 12:00 AM. The message is erased and the repeat interval is set to NONE.

To clear an appointment, display the appointment-setting menu for the appointment and press **■** **CLEAR DATA**.

To clear all ten appointments, display the APPT menu (the menu with menu keys **■** **RPT1**, **■** **RPT2**, etc.) and press **■** **CLEAR DATA** **■** **YES**.

Example: Setting and Clearing an Appointment. Today is Friday, April 15, 1988. You want to set an appointment to go off every Tuesday at 2:15 p.m. to remind you of a staff meeting. The example assumes 12-hour time format and month/day/year date format.

Keys:	Display:	Description:
TIME		Displays the APPT menu.
APPT		
RPT4		Displays the setting for appointment #4.
CLEAR DATA		Clears the appointment.
2.15 TIME	4: FRI 04/15/88 2:15A	Stores appointment time; sets current date.
R/PM	4: FRI 04/15/88 2:15P	Sets PM.
4.19 DATE	4: TUE 04/19/88 2:15P	Stores appointment date using the current year.
MSG		Stores the message.
STAFF INPUT		
RPT		Displays the RPT menu.
1 WEEK	RPT=1 WEEK(S) 4: TUE 04/19/88 2:15P	Sets the repeat interval.
EXIT	SET:4	Returns to the APPT menu. Appointment #4 is "set."

Date Arithmetic

The CALC menu does date arithmetic—finding the number of days between two dates, or determining the date a given number of days in the future or past. Date arithmetic uses one of three calendars—actual, 365-day, or 360-day (see table 7-3). The CALC menu also determines the day of the week for any date.

To display the CALC menu, press **TIME**, then **CALC**.

Table 7-3. The CALC Menu for Date Arithmetic

Menu Key	Description
DATE1 DATE2	Stores or calculates a date using the current date format—month/day/year (MM.DDYyyy) or day.month.year (DD.MMYyyy); also displays the day of the week. If you omit Yyyy, the calculator uses the current year.
DAYS	Stores or calculates the number of days between DATE1 and DATE2 using the actual calendar, which recognizes leap years.
360D	Calculates the number of days between DATE1 and DATE2 using the 360-day calendar, which uses 12, 30-day months.
365D	Calculates the number of days between DATE1 and DATE2, using the 365-day calendar, which ignores leap years.
TODAY	Displays the current date.

Determining the Day of the Week for Any Date

To find the day of the week for any date, key in the date and press **DATE1** or **DATE2**.

Calculating the Number of Days Between Dates

To calculate the number of days between two dates, starting from the TIME CALC menu:

1. Key in the first date in the current date format and press **DATE1**.
2. Key in the second date and press **DATE2**.
3. Press **DAYS**, **360D**, or **365D** to calculate the number of days using that calendar.

Example: Calculating the Number of Days Between Two

Dates. Find the number of days between April 20, 1982 and August 2, 1986, using both the actual calendar and the 365-day calendar. Assume the date format is month/day/year.

Keys:	Display:	Description:
TIME CALC		Displays the CALC menu.
4.201982 DATE1	DATE1= 04/20/1982 WED	Stores the first date and displays day of the week.
8.021986 DATE2	DATE2= 08/02/1986 SAT	Stores the second date.
DAYS	ACTUAL DAYS= 1,565.0000	Calculates number of days (actual calendar).
365D	365 DAYS= 1,564.0000	Calculates number of days (365-day calendar).

Calculating Past or Future Dates

To calculate a date a specified number of days from another date:

1. Key in the known date in the current date format and press **DATE1**.
2. Key in the number of days. If the unknown date precedes the known date, press **[+/-]**. Press **DAYS**. (You must use the actual calendar).
3. Press **DATE2**.

Example: Determining a Future Date. On February 9, 1989, you purchase a 120-day option on a piece of land. Determine the expiration date. Assume the date format is month/day/year.

Keys:	Display:	Description:
TIME CALC		Displays the CALC menu.
2.091989 DATE1	DATE1= 2/09/1989 THU	Stores DATE1.
120 DAYS	ACTUAL DAYS= 120.0000	Stores the number of days in the future.
DATE2	DATE2= 6/09/1989 FRI	Calculates the expiration date.

Clearing the Date Arithmetic Variables

DATE1, *DATE2*, and *DAYS* remain in memory until they are cleared. To clear them, display the TIME CALC menu and press

CLEAR DATA.

Printing

The calculator can print information using the HP 82240A Infrared Printer, which accepts the infrared signal generated by the printer port. This chapter describes the types of information you can print. Operation of the printer is covered in the printer owner's manual.*

The print annunciator () comes on whenever the calculator sends information through its printer port.

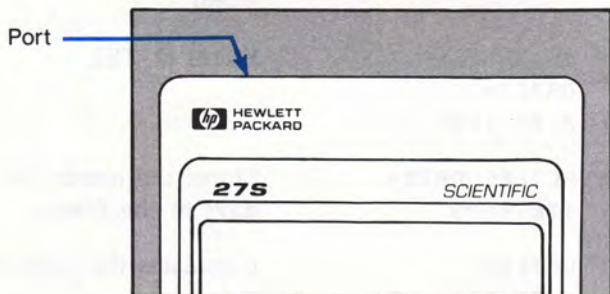



Figure 8-1. The Infrared Printer Port

Because communication goes only one way (from the calculator to the printer), the calculator cannot determine whether the printer is receiving information.

To preserve battery power, the HP-27S will not transmit data to the printer when the low batteries annunciator () is on. If low battery power occurs after you've started printing, printing stops and the calculator displays **BATT TOO LOW TO PRINT**.

* Since the HP-27S cannot send control characters to the printer, portions of the printer's manual pertaining to control codes and graphics characters do not apply.

Printing Speed and the Printer's Power Source

The speed with which the printer can print a line of information depends on whether it is using its optional AC adapter. To optimize printing performance, set the calculator's PRNT (print-speed) mode to match the power source of the printer. To view and/or change the print-speed mode:

1. Press **MODES** **MORE**.
2. Press **PRNT** to change the mode. A message indicates the new mode. If necessary, press **PRNT** again to set the desired message:
 - **PRINTER: AC ADAPTER** (printing *with* printer optional AC adapter).
 - **PRINTER: NO AC ADAPTER** (printing *without* the printer AC adapter).
3. Press **EXIT**.

For print operations involving large amounts of information, printing is faster using the printer's AC adapter and the calculator's appropriate PRNT mode. When the printer is powered by batteries alone, set the mode to **PRINTER: NO AC ADAPTER** so that the calculator will not transmit data too rapidly.

Printing the Calculator Line (**PRT**)

Press **PRT** to print the current contents of the calculator line. The entire contents of the calculator line is printed, including characters that have scrolled off the display. In the SOLVE menu, pressing **PRT** prints the current equation.

Printing Other Information (**PRINTER**)

The **PRINTER** menu allows you to print most of the information you've stored, including variables, lists, appointments, the history stack, registers, and the current date and time. You can also print messages to label the output.

In addition to printing specific information, you can produce a record of your calculations and other keystrokes (tracing).









To display the **PRINTER** menu, press  **PRINTER**.

Table 8-1. The **PRINTER Menu**

Menu Key	Description
 LIST	Prints data associated with the current menu (see "Printing Variables, Lists, and Appointments," below).
 STK	Prints the history stack.
 REGS	Prints the contents of registers 0 through 9.
 TIME	Prints the current date and time.
 MSG	Displays the ALPHA menu for typing a message.
 TRACE	Switches between <i>trace on</i> and <i>trace off</i> modes. See "Trace Printing" on page 152.

Printing amortization tables is covered in chapter 6.

Printing Variables, Lists, and Appointments

The operation performed by  **LIST** is menu-dependent; the information printed varies from menu to menu.

Printing Variables. When a menu consists of variables, **PRINTER** **LIST** prints those variables. For example:

- In the %CHG menu, *OLD*, *NEW*, and *%CH* are printed.
- In the STAT CALC menu, *TOTAL*, *MEAN*, *MEDN*, *STDEV*, *RANG*, *MIN*, and *MAX* are printed.
- In a menu of variables for a Solver equation, those variables are printed.

Printing Number Lists. When the HP-27S is displaying the top-level STAT menu, **PRINTER** **LIST** prints the contents of the current list.

Printing Solver Equations. To print one or all of the Solver equations, display the top-level SOLVE menu. Then:

- To print the current equation, press **PRT**.
- To print the entire equation list, press **PRINTER** **LIST**.

Printing Appointments. To print all stored appointments, display the APPT menu (the menu displayed when you press **APPT**) and press **PRINTER** **LIST**.

Menus Not Associated With Stored Data. Many menus do *not* have stored information associated with them. Pressing **PRINTER** **LIST** while viewing these menus prints no information. For example, the HYP and BASE menus have no stored data. Similarly, menus such as the GET menu in the STAT application and the SET menu in the TIME application are activity-oriented menus, and no information is printed.

Printing Descriptive Messages

You can include messages to label your printed output. Pressing **PRINTER** **MSG** displays the ALPHA menu. Type the message and press **INPUT** to transmit it to the printer.

Trace Printing

Trace printing produces a record of all the keys you've pressed and the calculated results. To switch trace printing on and off:

1. Press **PRINTER**.
2. Press **TRACE** to change the setting. A message informs you that tracing is on or off. If necessary, press **TRACE** again to display the desired message.
3. Press **EXIT**.

You should turn tracing off when you are not using it, since transmitting data uses calculator battery power and slows calculator operation.

Example: Trace Printing an Arithmetic Calculation. Produce a record of the keystrokes you use to do the following calculation and store the result in the %CHG variable *OLD*.

$$\frac{1}{12} \times 4,800 + 125$$

Keys:

PRINTER **TRACE** *

EXIT

%CHG

12 **1/x**

x

4800 **+**

125 **OLD**

PRINTER

TRACE

EXIT

Printed Record:

EXIT

%CHG

12.0000 1/x

0.0833 ***

x

4,800.0000 +

125.0000 OLD

525.0000 ***

PRINTER

TRACE

* If the HP-27S displays PRINT MODE: TRACE OFF, press **TRACE** again.

Interrupting the Printer

To stop the transmission of data to the printer during long operations, press any key. The printer may continue to print additional information, since information is stored temporarily in the printer during certain print operations.

Additional Examples

Vector Calculations

The following examples use polar/rectangular coordinate conversions to do vector operations.

Adding Two Vectors in Polar Coordinates

The sum of two vectors $\vec{u} = 20i + 30j$ and $\vec{v} = 15i + 20j$ is $\vec{u} + \vec{v}$.

Example: A ship travels 150 miles on a course 60° east of north, and then travels an additional 80 miles on a course 15° west of north. How far is the ship from its starting point?

In what direction must the ship travel to return to its starting point? Angles are measured counterclockwise from 0° . East is 90° .



Additional Examples

Vector Calculations

The following examples use polar/rectangular coordinate conversions to do vector operations.

Adding Two Vectors in Polar Coordinates

The sum of two vectors $x_1\mathbf{i} + y_1\mathbf{j}$ and $x_2\mathbf{i} + y_2\mathbf{j}$ is $(x_1 + x_2)\mathbf{i} + (y_1 + y_2)\mathbf{j}$.

Example: A ship travels 150 miles on a course 60° east of north, and then travels an additional 80 miles on a course 15° west of north. How far is the ship from its starting point?

In what direction must the ship travel to return to its starting point? Angles are measured counterclockwise from 0° . East is 0° .

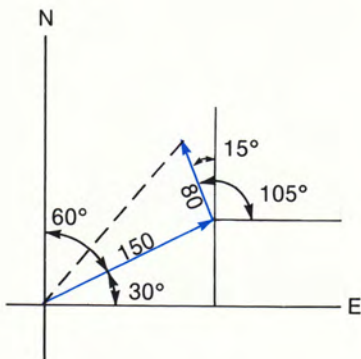

Keys:***Display:****Description:**

CONVERT

MORE

Displays the coordinate conversion variables.

If the **RAD** annunciator is on, press **D/R** to set Degrees mode.

150 **R** RADIUS=150.0000
30 **∠** ∠=30.0000

Enters first leg.

XCORD **STO** 1 XCOORD=129.9038

Stores x_1 in R_1 .

YCORD **STO** 2 YCOORD=75.0000

Calculates y_1 and stores value in R_2 .

80 **R** RADIUS=80.0000
105 **∠** ∠=105.0000

Enters second leg.

XCORD **STO**
+ 1 XCOORD=-20.7055

Calculates x_2 and adds it to contents of R_1 .

YCORD **STO**
+ 2 YCOORD=77.2741

Calculates y_2 and adds value to contents of R_2 .

RCL 1 **XCORD** XCOORD=109.1983

Stores $x_1 + x_2$ in **XCOORD**.

RCL 2 **YCORD** YCOORD=152.2741

Stores $y_1 + y_2$ in **YCOORD**.

R RADIUS=187.3810

Calculates distance from starting point.

* This problem, and the Law of Cosines problem on page 162 can be done using the Solver equation:

$$\text{IF}(S(\text{ANG}) : \text{ANGLE}(\text{XCOORD}(R1 : A1) + \text{XCOORD}(R2 : A2) : \text{YCOORD}(R1 : A1) + \text{YCOORD}(R2 : A2)) - \text{ANG} : \text{RADIUS}(\text{XCOORD}(R1 : A1) + \text{XCOORD}(R2 : A2) : \text{YCOORD}(R1 : A1) + \text{YCOORD}(R2 : A2)) - R)$$

where vector (R, ANG) is the sum of vectors $(R1, A1)$ and $(R2, A2)$, and all vectors are expressed in polar coordinates.

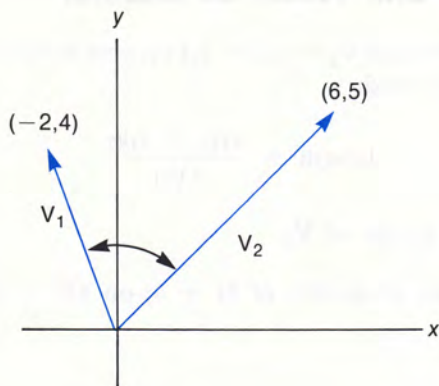

Keys:*

Display:

Description:

CONVERT

Displays the coordinate conversion variables.

MORE

If the **RAD** annunciator is on, press **D/R** to set Degrees mode.

2 **+/-** **XCORD**

XCOORD=-2.0000

Stores x and y for V_1 .

4 **YCORD**

YCOORD=4.0000

Δ

Δ=116.5615

Calculates Δ for V_1 .

- 6 **STO**

Stores x (6) for V_2 .†

XCORD

116.5651-6.0000

5 **STO**

Stores y (5) for V_2 .†

YCORD

116.5651-5.0000

Δ

116.5651-39.8056

Calculates Δ for V_2 .

=

76.7595

Calculates angle between V_1 and V_2 .

EXIT

Exits CONVERT menu.

* This problem can be done using the Solver equation:

$$ANG=ANGLE(X1:Y1)-ANGLE(X2:Y2)$$

where ANG is the angle between vectors (x_1, y_1) and (x_2, y_2) .

† You must use **STO** to store just the rightmost number. If necessary, refer to the rules for using menu variables on page 29.

Projection of One Vector on Another

The projection of vector $V_1 = x_1i + y_1j$ on vector $V_2 = x_2i + y_2j$ has the direction of V_2 and:

$$\text{Length} = \frac{x_1x_2 + y_1y_2}{|V_2|}$$

where $|V_2|$ is the length of V_2 .

Example: Find the projection of $6i + 4j$ on $10i - 2j$.

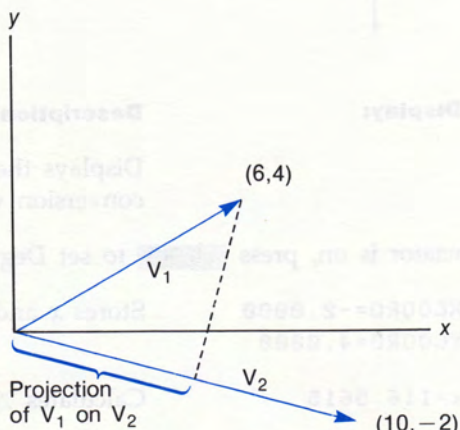

Keys:**Display:****Description:**

CONVERT

MORE

Displays the coordinate conversion variables.

If the **RAD** annunciator is on, press **D/R** to set Degrees mode.

10 **XCORD** XCOORD=10.0000

Calculates Δ for V_2 .

2 **+/-** **YCORD** YCOORD=-2.0000

Δ

Δ=-11.3099

R

RADIUS=10.1980

Calculates $|V_2|$.

1/x

0.0981

Calculates $1/|V_2|$.

x **(** 6 **x** 10

+ 4 **x** 2

+/- **)**

0.0981 × 52.0000

Calculates $x_1x_2 + y_1y_2$.

R

RADIUS=5.0990

Stores projection length.

XCORD

XCOORD=5.0000

Calculates x for projection.

YCORD

YCOORD=-1.0000

Calculates y for projection.

EXIT

Exits CONVERT menu.

The projection vector is $5i - 1j$.

Laws of Sines and Cosines

The law of sines and law of cosines apply to all triangles:

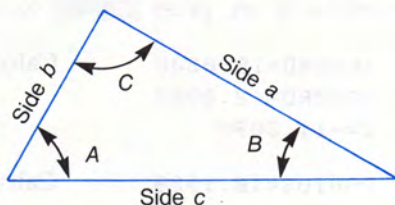

Law of sines:

$$\frac{a}{\sin A} = \frac{b}{\sin B} = \frac{c}{\sin C}$$

Use when you know:

- One side, two angles.
- Two sides, angle opposite a known side.

Law of cosines:

$$a^2 = b^2 + c^2 - 2bc \cos A$$

Use when you know:

- Two sides, angle between them.
- Three sides.

Example: Law of Sines. You look down from the top of a 5000-foot mountain with your telescope and see two large water towers, one behind the other. When you point the telescope at one tower, the angle from horizontal is 33° . For the other tower, the angle from horizontal is 48° . How far apart are the towers?

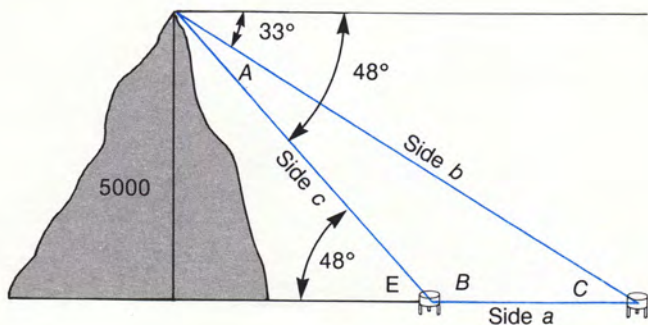

The unknown is side a of triangle ABC . Angles A , B , and C are easily found:

$$A = 48 - 33 = 15^\circ$$

$$B = 180 - 48 = 132^\circ$$

$$C = 180 - (15 + 132) = 33^\circ$$

Side a can be calculated using the law of sines if we know any other side. We do, since $c \sin E = 5000$, and $E = 180 - 132 = 48^\circ$. Therefore, $c = 5000 \div \sin 48^\circ$.

If the **RAD** annunciator is on, press **MODE** **MORE** **D/R** **EXIT** to set Degrees mode.

Keys:

Display:

Description:

5000 \div 48

SIN **=**

6,728.1636

Calculates side c .

Now, use the law of sines to calculate side a ; $a = c \sin A \div \sin C$:

\times 15 **SIN** \div

1,741.3769÷

33 **SIN** **=**

3,197.3046

Calculates side a .

Example: Law of Cosines. A plane travels north for 175 miles before turning around. On the return trip, a strong wind from the east pushes the plane 18° off course. After traveling 150 miles, how far is the plane from the airport?

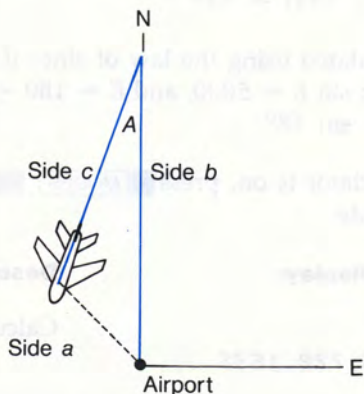

Two sides and the angle between them are known:

$$b = 175$$

$$c = 150$$

$$A = 18^\circ$$

By the law of cosines, $a = \sqrt{b^2 + c^2 - 2bc \cos A}$

If the **RAD** annunciator is on, press **MODES** **MORE** **D/R** **EXIT** to set Degrees mode.

Keys:	Display:	Description:
175 x² +	30,625.0000+	
150 x² -	53,125.0000-	
2 x 175 x 150 x	...25.0000- 52,500.0000x	
18 COS	...0-52,500.0000x 0.9511	Calculates cosine of 18° .
= √x	56.5202	Distance from airport.

Probability Calculations

The following calculations use the PROB menu and the relationship:

$$\text{Probability of an event} = \frac{\# \text{ of combinations that produce the event}}{\text{total \# of combinations}}$$

A company employing 14 women and 10 men is forming a six-person committee to deal with health and safety issues.

Part 1: How many different combinations of people are possible?

Keys:

Display:

Description:

PROB

Displays the PROB menu.

24 **X** X=24.0000

Stores number of employees.

6 **Y** Y=6.0000

Stores committee size.

C X,Y C X,Y=134,596.0000

Calculates number of combinations.

Part 2: If employees are chosen at random, what is the probability that the committee will contain six women?

STO 1 C X,Y=134,596.0000 Stores previous result.

14 **X** X=14.0000 Stores number of women employees.

C X,Y C X,Y=3,003.0000 Calculates number of combinations of six women.

+ RCL 1 = 0.0223 Probability of committee being all women.

Part 3: If employees are chosen at random, what is the probability that the committee will contain equal numbers of men and women?

10 \times $X=10.0000$ Calculates combinations
3 $Y=3.0000$ of 10 men, 3 at a time.

C X, Y $C X, Y=120.0000$

\times 14 STO Stores number of women
 X 120.0000×14.0000 employees.

C X, Y 120.0000×364.0000 Calculates combinations
of 14 women taken 3 at a
time.

$=$ $43,680.0000$ Number of 6-person
committees with 3 men
and 3 women.

\div RCL 1 $=$ 0.3245 Probability of the com-
mittee containing 3 men
and 3 women.

Part 4: The Safety Officer, Billy Johnson, *must* be on the committee. How many combinations are possible? (Since one employee *must* be on the committee, there are five openings for the 23 remaining employees.)

23 X $X=23.0000$ Number of combinations
5 $Y=5.0000$ of 23 taken 5 at a time.

C X, Y $C X, Y=33,649.0000$

Part 5: Once the committee members are chosen, how many ways can they arrange themselves in a room containing six chairs?

There are $6!$ ways of seating themselves:

6 NI 720.0000 Calculates $6!$.

Part 6: If there are 7 chairs in the room, how many seating arrangements are possible?

7 X=7.0000

6 Y=6.0000

P X,Y=5,040.0000

Permutations of 7 taken
6 at a time.

Exits PROB menu.

Simulating a Toss of Dice

The Solver random number function RAN# can simulate the toss of one or more six-sided dice. The equation:

$$\text{TOSS}=\text{IP}(\text{RAN}\#\times 6+1)$$

generates integers in the range 1 through 6. Similarly,

$$\text{TOSS}=\text{IP}(\text{RAN}\#\times 6+1)+\text{IP}(\text{RAN}\#\times 6+1)$$

simulates the toss of two dice.

1. To enter the equation, press , then .
2. Type the equation for the appropriate number of dice and press .
3. Press to verify the equation and display the menu of variables.
4. Press as many times as desired to see the results of the tosses.

Motion of a Projectile

The equations:

$$x = v_0 t \cos A$$

and

$$y = h + v_0 t \sin A - \frac{1}{2} g t^2$$

define the position of a projectile at time t after it was fired with initial altitude h , initial velocity v_0 feet/second, and initial trajectory of angle A from the horizontal axis. g is a constant, the acceleration of gravity (32 feet/second²).

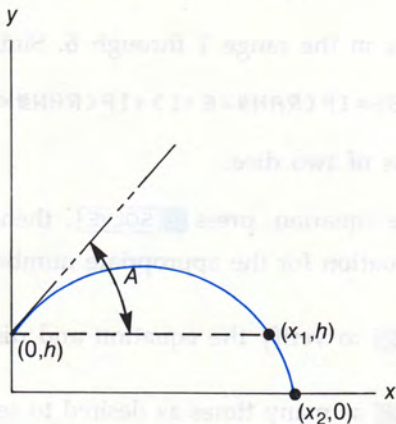

The S (solving for) function allows the two equations to be grouped together in one Solver equation:

$$\text{IF}(S(X): X - V_0 \times T \times \cos(A) : Y - H - V_0 \times T \times \sin(A) + .5 \times G \times T^2)$$

The expression $X - V_0 \times T \times \cos(A) = 0$ is used when solving for x ; otherwise, $Y - H - V_0 \times T \times \sin(A) + .5 \times G \times T^2 = 0$ is used.

Example: Shot-putter Hi Hurler can throw a shot-put with an initial velocity of 34 feet/second. If the initial angle of the trajectory is 43° , and the shot-put is released at a height of 5 feet, how far can Hi throw? What is the highest altitude the shot-put reaches?

1. To enter the equation, press **SOLVE**, then **NEW**.
2. Type the Solver equation and press **INPUT**.
3. Press **CALC** to verify the equation and display the menu of variables.

If the **RAD** annunciator is on, press **MODES** **MORE** **D/R** **EXIT** to set Degrees mode.

Since X is a function of T , you must first solve for T .

Keys:	Display:	Description:
34 V0	$V0=34.0000$	Stores initial velocity.
43 A	$A=43.0000$	Stores angle.
0 Y	$Y=0.0000$	Stores final altitude.
MORE		Stores release height.
5 H	$H=5.0000$	
32 G	$G=32.0000$	Stores constant.
MORE		Stores guesses for T .
1 T	$T=1.0000$	
5 T	$T=5.0000$	
T	$T=1.6398$	Calculates flight time.
X	$X=40.7757$	Calculates x_2 , the horizontal distance.

The maximum altitude occurs in exactly half the time it takes the shot-put to fly from $(0,h)$ to (x_1,h) .

5 **Y** $Y=5.0000$

Stores altitude at point $(0,h)$.

T $T=1.4492$

Calculates time required to reach (x_1,h) .

+ 2 **T** $T=0.7246$

Calculates time to reach maximum altitude and stores value in T .

Y $Y=13.4013$

Calculates maximum altitude.

The Catenary Equation

The curve formed by suspending a flexible cable from two points is called a *catenary*, and is defined by the equation:

$$y = a \cosh(x/a)$$

The length of the cable is calculated by the equation:

$$L = 2a \sinh(x/a)$$

where a is the lowest height of the cable and L is the cable length.

Example: You want to suspend a cable between two poles that are 40 feet apart. The cable must pass under a tree limb 25 feet high located 5 feet from one of the poles. How far off the ground will the cable be at its lowest point?

At what height should the cable be attached to the poles?

What length of cable is needed?

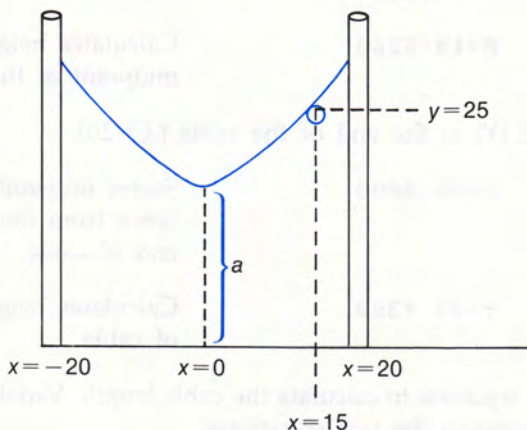

1. To enter the first equation, press **SOLVE**, then **NEW**.
2. Type $Y=A \times \text{COSH}(X \div A)$ **INPUT**.
3. Press **NEW** and type $L=2 \times A \times \text{SINH}(X \div A)$ **INPUT**.
4. Press **▲** to display the first equation.
5. Press **CALC** to display the menu of variables for the first equation.

Use the one point known (15,25) to calculate A.

Keys:	Display:	Description:
15 X	X=15.0000	Stores X.
25 Y	Y=25.0000	Stores Y.
10 A	A=10.0000	Stores guesses for A.
20 A	A=20.0000	
A	A=18.6268	Calculates height at the midpoint of the cable.

Find the height (Y) at the end of the cable (X=20):

20 X	X=20.0000	Stores horizontal distance from midpoint to end of cable.
Y	Y=30.4360	Calculates height at end of cable.

Use the second equation to calculate the cable length. Variables A and X are shared between the two equations:

EXIT ▼		Displays the second equation.
CALC		Displays the menu of variables.
L	L=48.1413	Calculates the cable length.

Distance Between Two Locations

If the longitude and latitude of two locations are known, the angle between them can be calculated by the equation:

$$\cos A = \sin LT1 \sin LT2 + \cos LT1 \cos LT2 \cos(LG1-LG2)$$

where A is the angle of the arc between the two points. The relationship between distance and angle of arc is:

$$1^\circ \text{ of arc} = 60 \text{ nautical miles} = \pi \times D \div 360 \text{ statute miles}$$

where D is the diameter of the earth, 7917.59 miles.

The following Solver equation calculates the approximate nautical or statute miles between two points. Angles are entered in Degrees.MinutesSeconds format (D.MMSSss). South Latitude and East Longitude are negative numbers. The calculator must be in Degrees mode.

$$\text{DISTANCE} = C \times \text{ACOS}(\text{SIN}(\text{HRS}(\text{LT1})) \times \text{SIN}(\text{HRS}(\text{LT2})) + \text{COS}(\text{HRS}(\text{LT1})) \times \text{COS}(\text{HRS}(\text{LT2})) \times \text{COS}(\text{HRS}(\text{LG1}) - \text{HRS}(\text{LG2})))$$

where C is a constant:

$C = 60$ to compute nautical miles.

$C = 69.0940$ compute statute miles.

Example: Find the statute miles between Philadelphia, Pennsylvania ($40^\circ 35' \text{N}$, $75^\circ 10' \text{W}$) and Corvallis, Oregon ($44^\circ 35' \text{N}$, $123^\circ 16' \text{W}$).

1. To enter the equation, press **SOLVE**, then **NEW**.
2. Type the equation and press **INPUT**.
3. Press **CALC** to verify the equation and display the menu of variables.

Keys:	Display:	Description:
69.0940 C	C=69.0940	Enters constant for statute miles.
40.35 LT1 75.10 LG1	LT1=40.3500 LG1=75.1000	Stores latitude and longitude for Philadelphia.
44.35 LT2 123.16 LG2	LT2=44.3500 LG2=123.1600	Stores latitude and longitude of Corvallis.
DISTA	DISTANCE= 2,426.9794	Calculates distance.

Leasing Calculations

Two common leasing calculations are calculating the lease payment necessary to achieve a specified yield, and finding the present (capitalized) value of a lease. Leasing calculations typically use Begin mode. For example, "one payment in advance" means that payments are made at the beginning of each period. For two payments in advance, add one extra payment to the present value.

Example: Calculating a Lease Payment. A new car valued at \$13,500 is leased for 3 years. The lessee has the option to purchase the car for \$7,500 at the end of the leasing period. What monthly payments, with one payment in advance, are necessary to yield the lessor 14% annually?

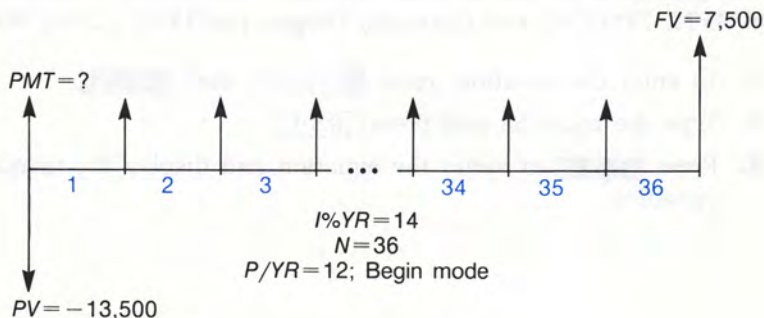

Keys:**Display:****Description:**

MODES

FIX

2 **INPUT**

TVM

Sets display to two decimal places.

Enters the TVM application.

OTHER

12 **P/YR**

BEG **EXIT**

12 P/YR BEGIN MODE

Sets payment conditions.

36 **N**

N=36.00

Stores number of payments.

14 **I%YR**

I%YR=14.00

Stores annual interest rate.

13500 **+/-**

PV

PV=-13,500.00

Stores lease amount.

7500 **FV**

FV=7,500.00

Stores purchase option value.

PMT

PMT=289.19

Calculates monthly payment received.

Example: Present (Capitalized) Value of a Lease with Advanced Payments and Option to Buy. Your company is leasing a machine for 4 years. Monthly payments are \$2,400 with two payments in advance. The leasing agreement includes an option to buy the machine for \$15,000 at the end of the leasing period. What is the capitalized value of the lease, assuming that the interest rate you pay to borrow funds is 18%, compounded monthly?

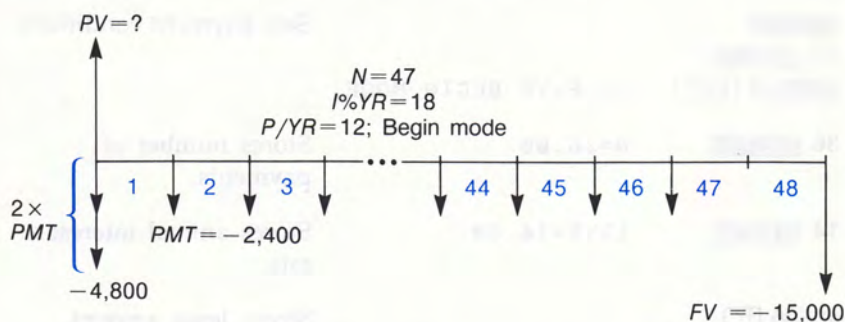

The problem is done in four steps:

1. With future value set to 0, calculate the present value of the 47 monthly payments.
2. Add to the calculated present value the additional advance payment.
3. Find the present value of the buy option.
4. Sum the present values calculated in steps 2 and 3.

Keys:**Display:****Description:**

MODES

FIX

2 INPUT

TVM

CLEAR DATA

OTHER

12 P/YR

BEG EXIT

12 P/YR BEGIN MODE

Sets display to two decimal places.

Enters the TVM application.

Optional; clears TVM variables.

Sets payment conditions.

Step 1: Find the present value of the monthly payments:

0 FV FV=0.00

Sets FV to 0; not necessary if you previously cleared the variables.

47 N N=47.00

Stores number of payments.

18 I%YR I%YR=18.00

Stores annual interest rate.

2400 +/-

PMT PMT=-2,400.00

Stores monthly payment.

PV PV=81,735.58

Calculates present value of the 47 monthly payments.

Step 2: Add the additional advance payment to PV. Store the answer.

+ 2400 = 84,135.58

Calculates present value of all the payments.

STO 0 84,135.58

Stores 84,135.58 in R₀.

Step 3: Find the present value of the buy option.

48	N	N=48.00	Stores number of payment periods.
15000	+/-		Stores the buy option.
	FV	FV=-15,000.00	
0	PMT	PMT=0.00	Sets $PMT=0$.
	PV	PV=7,340.43	Calculates present value of the buy option.

Step 4: Add the results of step 2 and 3.

+	RCL	0	=	91,476.00	Calculates the present (capitalized) value of the lease.
---	-----	---	---	-----------	--

Interest Rate Conversions

Interest rates are generally stated as *nominal interest rates*. A nominal interest rate is an annual rate that is compounded *periodically*—for example, 18% per year, compounded monthly. When investments have different compounding periods, *effective interest rates* are used to compare them. The effective rate is the rate that, *compounded annually*, would produce the same interest earnings as the nominal rate. For example, earning 18% annual rate compounded monthly (nominal rate) is equivalent to earning 19.56% annual interest, compounded annually (effective rate).

There are two compounding methods and two corresponding equations:

- Periodic compounding; for example, quarterly, monthly, or daily compounding.

$$EFF\% = \left[\left(1 + \frac{NOM\%}{100 \times P} \right)^P - 1 \right] \times 100$$

EFF% and NOM% are the effective and nominal percentage interest rates; P is the number of compounding periods per year.

- Continuous compounding.

$$EFF\% = \left(e^{\frac{NOM\%}{100}} - 1 \right) \times 100$$

The variables $NOM\%$ and $EFF\%$ are shared between the two equations.

To do interest conversion calculations:

1. Press **SOLVE**, then **NEW**.
2. Type the Solver periodic compounding equation:
PERCMPD:EFF%=(1+NOM%÷(100×P))^P-1)×100 **INPUT**
3. Press **NEW**. Type the Solver continuous compounding equation:
CONTCMPD:EFF%=(EXP(NOM%÷100)-1)×100 **INPUT**
4. Display the appropriate equation and press **CALC** to verify the equation and display the menu of variables.

Example: You are considering opening a savings account in one of three banks. Which bank has the most favorable interest rate to you?

Bank #1 6.7% annual interest, compounded quarterly

Bank #2 6.65% annual interest, compounded monthly

Bank #3 6.65% annual interest, compounded continuously

Display the menu of variables for the equation labeled PERCMPD by displaying the equation and pressing **CALC**.

Keys:	Display:	Description:
4 P	P=4.0000	Stores compounding periods/year for bank #1.
6.7 NOM%	NOM%=6.7000	Stores nominal annual rate for bank #1.
EFF%	EFF%=6.8702	Calculates effective rate for bank #1.
12 P	P=12.0000	Stores compounding periods/year for bank #2.
6.65 NOM%	NOM%=6.6500	Stores nominal annual rate for bank #2.
EFF%	EFF%=6.8565	Calculates effective rate for bank #2.
EXIT ▼		Displays the continuous compounding equation.
CALC		Displays the menu of variables.
EFF%	EFF%=6.8761	Calculates effective rate for bank #3.

Bank #3 is offering the most favorable interest rate.

Finding Several Roots of a Function

The function $f(x) = x^3 - 5x^2 - 10x + 20$ has three roots.

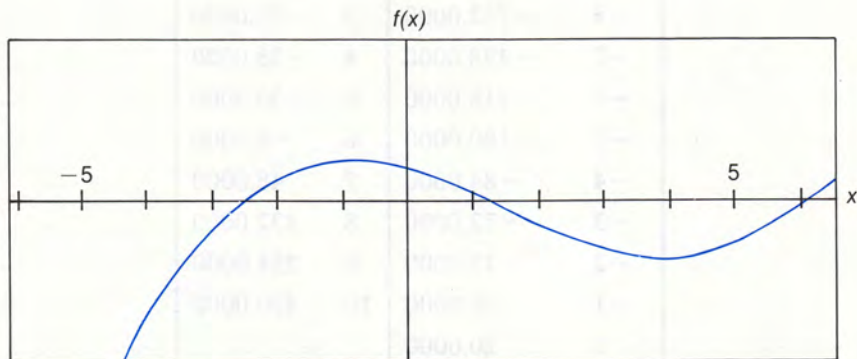

The Solver can find each root by entering appropriate guesses that bracket the root. One way to determine appropriate guesses is to evaluate the function at different values of x and look for places where $f(x)$ changes sign. To evaluate an equation, algebraically rearrange it so that all the terms are on the left, and set them equal to a “dummy” variable.

Example: To find the three roots of the function:

$$f(x) = x^3 - 5x^2 - 10x + 20 = 0$$

1. Press **SOLVE**, then **NEW**.
2. Set $f(x)$ equal to the “dummy” variable y by typing:
 $Y=X^3-5\times X^2-10\times X+20$ **INPUT**.
3. Press **CALC** to verify the equation and display the menu of variables.
4. Store various values of X and calculate Y :

X	Y	X	Y
-10	-1,380.0000	1	6
-9	-1,024.0000	2	-12.0000
-8	-732.0000	3	-28.0000
-7	-498.0000	4	-36.0000
-6	-316.0000	5	-30.0000
-5	-180.0000	6	-4.0000
-4	-84.0000	7	48.0000
-3	-22.0000	8	132.0000
-2	12.0000	9	254.0000
-1	24.0000	10	420.0000
0	20.0000		

Set $Y = 0$ and use the locations of the sign changes as initial guesses for X :

Keys:

Display:

Description:

0 \square Y \square

Y=0.0000

Stores 0 in Y.

3 \square +/- \square X \square

x=-3.0000

Stores guesses.

2 \square +/- \square X \square

X=-2.0000

\square X \square

X=-2.4433

Calculates first root.

1 \square X \square

X=1.0000

Stores guesses.

2 \square X \square

X=2.0000

\square X \square

X=1.3416

Calculates second root.

6 \square X \square

X=6.0000

Stores guesses.

7 \square X \square

X=7.0000

\square X \square

X=6.1017

Calculates third root.

Moving Average

Moving averages are often used to predict trends in data over time. In moving average calculations, a specified number of values are averaged. Each time a new value is acquired, the oldest is discarded.

The following Solver equation calculates the moving average of data stored in a STAT list:

$$\text{MAVG} = \Sigma \langle I : \text{MAX} \langle 1 : \text{LAST} - N + 1 \rangle : \text{LAST} : 1 : \text{ITEM} \langle \text{name} : I \rangle \rangle \\ \div \text{MIN} \langle \text{LAST} : N \rangle$$

where N is the number of values averaged in each calculation, LAST is the item number of the most recent value to be averaged, and name is the name of the STAT list.

1. Press **SOLVE** **NEW** and enter the equation.
2. Press **STAT** to enter the STAT application. Enter the values into a list. Name the list, making sure the name matches the name in the equation.
3. Press **SOLVE** to return to the Solver. Display the menu of variables for the equation (press **CALC**).
4. Key in the number of values to be averaged and press **N**.
5. For each average:
 1. Key in the item number of the last value in the set to be averaged and press **LAST**.
 2. Press **MAVG**.

Example: Calculate a three-month moving average for the number of units manufactured during the first half of the year. Manufacturing volumes were:

January	February	March	April	May	June
4400	5360	2900	3670	4040	3200

Enter the equation into the Solver, with *name* set to VOL. Then:

Keys:	Display:	Description:
<input type="button" value="MODES"/>		Sets display to two decimal places.
<input type="button" value="FIX"/>		
2 <input type="button" value="INPUT"/>		Enters the STAT application.
<input type="button" value="STAT"/>		

If you want to preserve the current list, skip the next step. Instead, press .

<input type="button" value="CLEAR DATA"/>		Enters data.
<input type="button" value="YES"/>		
4400 <input type="button" value="INPUT"/>		ITEM<7>=? TOTAL=23,570.00
5360 <input type="button" value="INPUT"/>		
2900 <input type="button" value="INPUT"/>		
3670 <input type="button" value="INPUT"/>		
4040 <input type="button" value="INPUT"/>		
3200 <input type="button" value="INPUT"/>		

<input type="button" value="EXIT"/> <input type="button" value="NAME"/>		Names the list VOL.
VOL <input type="button" value="INPUT"/>	ITEM<7>=?	
<input type="button" value="SOLVE"/>		Enters the Solver.

If necessary, use \blacktriangle or \blacktriangledown to display the moving average equation.

CALC		Displays menu of variables.
3 N	$N=3.00$	Stores number of points.
3 LAST MAVG	$MAVG=4,220.00$	Calculates average for months 1, 2, and 3.
4 LAST MAVG	$MAVG=3,976.67$	Calculates average for months 2, 3, and 4.
5 LAST MAVG	$MAVG=3,536.67$	Calculates average for months 3, 4, and 5.
6 LAST MAVG	$MAVG=3,636.67$	Calculates average for months 4, 5, and 6.

Chi-Squared (χ^2) Statistics

The Chi-squared statistic is a measure of the goodness of fit between data and an assumed distribution.* It is used to test whether a set of observed frequencies differs from a set of expected frequencies sufficiently to reject the hypothesis under which the expected frequencies were obtained. In other words, you are testing whether discrepancies between the observed frequencies (O_i) and the expected frequencies (E_i) are significant, or whether they may reasonably be attributed to chance. The equation is:

$$\chi^2 = \sum_{i=1}^n \frac{(O_i - E_i)^2}{E_i}$$

If there is close agreement between the observed and expected frequencies, χ^2 is small; if the agreement is poor, χ^2 is large.

* The statistic can be assumed to be χ^2 distributed with $n - 1$ degrees of freedom if n or some of the E_i values are large.

The following Solver equations calculate χ^2 using data in one or two STAT lists:

If the expected values vary:

$$1: \text{CHI2} = \Sigma(I:1:\text{SIZES}(name1):1: (\text{ITEM}(name1:I) - \text{ITEM}(name2:I))^2 \div \text{ITEM}(name2:I))$$

If the expected value is a constant:

$$2: \text{CHI2} = \Sigma(I:1:\text{SIZES}(name1):1: (\text{ITEM}(name1:I) - \text{EXPT})^2 \div \text{EXPT})$$

where:

name1 = the name of the list containing the observed values.

name2 = the name of the list containing the expected values.

EXPT = the expected value, if constant.

1. Press **SOLVE** **NEW** and enter the appropriate equation(s).
2. Press **STAT** to enter the STAT application. Enter the observed values into a list. Name the list, making sure the name matches *name1* in the equation.
3. If the expected values vary, enter them into a second list. Name the list, making sure the name matches *name2* in the equation.
4. Press **SOLVE** to return to the Solver. Display the appropriate equation and press **CALC**.
5. If the expected value is a constant, key in the value and press **EXPT**.
6. Press **CHI2**.*



Example: To determine whether a suspect die is biased, you toss it 120 times and observe the following results. (The expected frequency is the same for each number, $120 \div 6$.)

Number	1	2	3	4	5	6
Observed Frequency	25	17	15	23	24	16







* If the HP-27S doesn't display CALCULATING . . . , press **CHI2** again.



Enter the second χ^2 equation into the Solver, with *name1* set to OB. Then:

Keystrokes:	Display:	Description:
		Enters the STAT application.



If you want to preserve the current list, skip the next step. Instead, name the list and then press  .





		Clears the list.
	ITEM(1)=?	

25 		Enters observed values.
17 		
15 		
23 		
24 		
16 	ITEM(7)=? TOTAL=120.0000	

 		Names the list OB.
OB 	ITEM(7)=?	

		Enters the Solver.
---	--	--------------------

If necessary, use  or  to display the second χ^2 equation.

		Displays menu of variables.
120  6		Stores expected value.
	EXPT=20.0000	
	CHI2=5.0000	Calculates χ^2 .

The number of degrees of freedom is $(n-1)=5$. Consult statistical tables to find χ^2 to a significance level of 0.05 with 5 degrees of freedom. The table shows that $\chi^2_{0.05,5} = 11.07$. Since the computed value (5.00) is less than 11.07, you can conclude that, to a 0.05 significance level (95% probability), the die is fair.

Calculating Subtotals

The following Solver equation calculates subtotals of a STAT list:

$$\text{STOTL} = \Sigma \langle I : \text{START} : \text{STOP} : 1 : \text{ITEM}(\text{name} : I) \rangle$$

where *START* and *STOP* define range of items subtotaled—*ITEM*(*START*) through *ITEM*(*STOP*), and *name* is the name of the STAT list containing the data.

1. Press **SOLVE** **NEW** and enter the equation.
2. Press **STAT** to enter the STAT application. Enter your data.
3. Name the list, making sure the name matches *name* in the equation.
4. Press **SOLVE** to return to the Solver. Display the menu of variables for the equation (press **CALC**).
5. Store values for *START* and *STOP* by keying in the values and pressing the menu keys.
6. Press **STOTL** to calculate the subtotal.

Example: You have collected the following data. Calculate the subtotals for observations 1-3, 1-4, and 2-6.

Observation	1	2	3	4	5	6
Value	25.1	12.7	35.7	27.2	18.9	10.3

Enter the equation into the Solver, with *name* set to DATA. Then:

Keys:

Display:

Description:

MODES

Sets display to one decimal place.

FIX

1 **INPUT**

STAT

Enters the STAT application.

If you want to preserve the current list, skip the next step. Instead, press **GET** ***NEW**.

CLEAR DATA

Clears the list.

YES ITEM<1>=?

25.1 **INPUT**

Enters the data.

12.7 **INPUT**

35.7 **INPUT**

27.2 **INPUT**

18.9 **INPUT**

10.3 **INPUT**

ITEM<7>=?

TOTAL=129.9

EXIT **NAME**

Names the list DATA.

DATA **INPUT** ITEM<7>=?

SOLVE

Enters the Solver.

If necessary, use **▲** or **▼** to display the subtotal equation.

CALC

Displays the menu of variables.

1 **START** START=1.0

Calculates subtotal for items 1, 2, and 3.

3 **STOP** STOP=3.0

STOTL STOTL=73.5

4 **STOP** STOP=4.0

Calculates subtotal for items 1, 2, 3, and 4.

STOTL STOTL=100.7

2 **START** START=2.0

Calculates subtotal for items 2 through 6.

6 **STOP** STOP=6.0

STOTL STOTL=104.8

Number of Days Until a Special Day

The following equation calculates the number of days between today's date and some other meaningful date within one year from today—for example, Christmas. The calendar in the TIME application must be set properly.

$$\text{SANTA} = \text{DDAYS}(\text{CDATE} : \overbrace{12.25}^{\text{Christmas}} + .01 \times \text{FP}(\text{CDATE} \times 100 + \underbrace{\text{IF}(\text{CDATE} \leq 12.25 + .01 : 0 : 1E-4)}_{\text{Christmas}})) : 1)$$

For other special days, replace 12.25 with the special day, expressed in MM.DD format.

1. To enter the equation, press **SOLVE**, then **NEW**.
2. Type the equation and press **INPUT**.
3. Press **CALC** to verify the equation and display the menu of variables.

Example: If today is April 20, 1988, how many days remain until Christmas?

Keys:

Display:

Description:

SANT

SANTA=249.0000

Calculates number of days until 12/25/1988.

A



Assistance, Batteries, Memory, and Service









Obtaining Help in Operating the Calculator

Hewlett-Packard is committed to providing the owners of HP calculators with ongoing support. You can obtain answers to your questions about using the calculator from our Calculator Technical Support department (see the address and phone number on the inside back cover).

We suggest that you read, "Answers to Common Questions", below, before contacting us. Past experience has shown that many of our customers have similar questions about our products.

Answers to Common Questions

- Q.** How can I determine if the calculator is functioning properly?
- A.** Refer to page 198, which describes the diagnostic self-test.
- Q.** How do I change the way numbers are formatted in the display?
- A.** See "Display Mode and Format of Numbers" on page 30.
- Q.** My numbers contain commas instead of periods as decimal points. How do I restore the periods?
- A.** Changing the decimal point is covered on page 34.
- Q.** How do I clear all or portions of memory?
- A.**  CLEAR DATA clears various portions of memory, depending on which menu the HP-27S is displaying. (See  in the index for page references.) Erasing the entire contents of memory is covered on page 196.

- Q.** Why does calculating the sine of π radians display a very small number instead of 0?
- A.** The calculator is *not* malfunctioning. π cannot be expressed *exactly* with the 12-digit precision of the calculator.
- Q.** Why do I get incorrect answers when I use the trig functions?
- A.** You must be in the correct angle mode—radians or degrees. The **RAD** annunciator is on in radians mode. Angles in degrees are interpreted as *decimal* degrees (*not* Degrees.MinutesSeconds).
- Q.** Why do I get the wrong answer using the TVM application?
- A.** Before beginning a TVM calculation, be sure to clear the TVM variables (), set the appropriate payment mode, and specify the number of payments per year ().
- Q.** How do I indicate multiplication in a Solver equation?
- A.** You must use the multiplication sign (). You cannot use the  key. Also, you cannot specify implied multiplication using parentheses.
- Q.** The calculator has displayed **INSUFFICIENT MEMORY**. What should I do?
- A.** Refer to “Managing Calculator Memory” on page 194.
- Q.** The calculator is operating slowly and the  annunciator is blinking. Why?
- A.** The calculator is in trace mode for printing. Press    to turn off tracing.
- Q.** Why doesn't the HP-27S beep when an appointment comes due?
- A.** The beeper has been turned off (see page 35).

Power and Batteries

The HP-27S is shipped with three mercury batteries. A fresh set of three mercury or silver oxide batteries provides approximately a year of normal use. (Alkaline batteries last about half as long.) However, expected battery life depends on how the calculator is used. Printing and long computations require much more power than other operations.

Use only fresh, button-cell batteries. Do not use rechargeable batteries. The following batteries are recommended for use. Not all batteries are available in all countries.

Mercury	Alkaline	Silver Oxide
Panasonic NP675	Panasonic LR44	Panasonic SR44W or SP357
Duracell MP675H	Varta V13GA	Eveready 357
Toshiba NR44 or MR44	Eveready A76	Ray-O-Vac 357
Radio Shack NR44 or MR44	Duracell LR44	Varta V357
Eveready EP675E		

Low-Power Indications

When the low-battery annunciator () comes on, the calculator can continue normal operations for several hours. If the calculator is turned off, Continuous Memory will be preserved for approximately two weeks. To conserve battery power, printing does not function when the battery annunciator is on. Printing may halt during a printing operation due to a borderline low battery condition; the calculator can detect insufficient power for printing before the battery annunciator comes on.

If you continue to use the calculator after the battery annunciator comes on, power can eventually drop to a level at which the calculator stops powering the display and keyboard. The calculator will require fresh batteries before it can be turned on. When you turn the calculator on after fresh batteries have been installed, the HP-27S displays MACHINE RESET if your stored data is intact or MEMORY LOST if data has been lost. In either case, the clock may be incorrect.

Installing Batteries

Once the batteries are removed, you must replace the batteries within one minute to prevent loss of Continuous Memory. Therefore, you should have the new batteries readily at hand before opening the battery compartment. Also, you must make sure the calculator is off during the entire process of changing batteries.

To install batteries:

1. Have three fresh button-cell batteries ready at hand. Make sure no appointment will come due while the batteries are out.
2. Make sure the calculator is *off*. **Do not press CLR (ON) again until the entire procedure for changing batteries is completed. Changing batteries with the calculator on could erase the contents of Continuous Memory.** (If you have set any appointments, make sure they will not come due while the batteries are out.)
3. Hold the calculator as shown. To remove the battery-compartment door, press down and outward on the ribbed area until the door slides off.

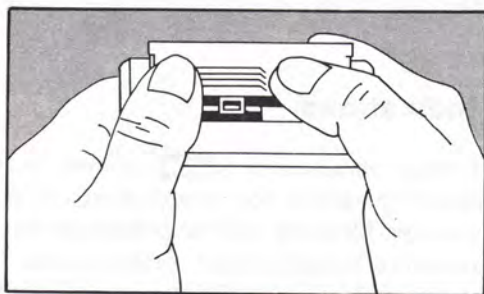

4. Turn the calculator over and shake the batteries out.



Warning

Do not mutilate, puncture, or dispose of batteries in fire. The batteries can burst or explode, releasing hazardous chemicals.

5. Hold the calculator as shown and stack the batteries, one at a time, in the battery compartment. Orient the batteries according to the diagram inside the battery compartment. Be sure the raised and flat ends match the diagram.

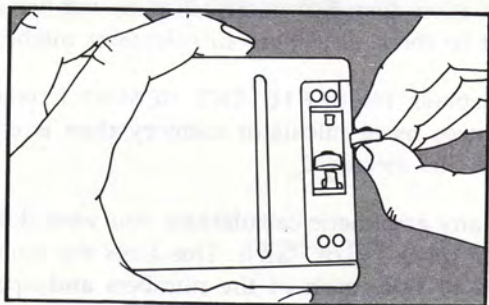

6. Slide the tab of the battery-compartment door into the slot in the calculator case, as shown.

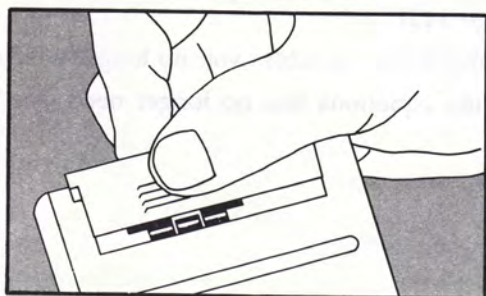

If the calculator does not function properly after the new batteries are installed, you might have taken too long or inadvertently turned the calculator on while the batteries were out. Remove the new batteries and lightly press a coin against both battery contacts in the calculator for a few seconds. Put the batteries back in and turn the calculator on; it should display **MEMORY LOST**.

Managing Calculator Memory

The HP-27S has approximately 6,900 units (or “bytes”) of memory available for your use. Table A-1 describes the memory requirements of stored information. Non-Solver variables are not listed, since memory is allocated to them elsewhere in calculator memory.

The HP-27S displays **INSUFFICIENT MEMORY** if you attempt an operation that uses more calculator memory than is currently available. If you see this message:

1. Complete any arithmetic calculations you were doing in the calculator line (press [=] or [CLR]). This frees the memory that was being used to store each of the numbers and operators.
2. To further reduce the amount of occupied memory, you can:
 - Rename your STAT lists to shorter names (see page 74), and clear any lists you no longer need (see page 76).
 - Shorten or delete any messages associated with appointments (see page 142).
 - Delete any Solver variables you no longer need (see page 95).
 - Delete any equations you no longer need (see page 95).

Table A-1. Memory Requirements

Type of Information	Amount of Memory Used
STAT number lists (excluding the list name)	16 bytes per list + 8 bytes for each item.
STAT list names	1 byte + 1 byte for each character in the name.
Equations	10½ bytes per equation + 1 byte for each character in the equation.*
Solver variables	15 bytes for each variable + 1 byte for each character in the variable name.
Calculator line	Numbers—8 bytes + 1 byte for each character. Operators—3½ bytes.
Appointment messages	41 bytes for the first message stored + 1 byte for each character in each message.

* An equation's memory requirements increase substantially while displaying its menu of variables.

Resetting the Calculator

If the calculator doesn't respond to keystrokes or is behaving unusually, attempt to reset it. Reset halts the current calculation, clears the calculator line, and displays the MAIN display. Stored data remains intact.

To reset the calculator, hold down the **CLR** key while you press the third menu key from the left. It may be necessary to repeat the reset keystrokes several times. The HP-27S displays MACHINE RESET to confirm that reset has occurred.

A machine reset may occur automatically if the calculator is dropped or if power is interrupted.

Erasing Continuous Memory

Erasing Continuous Memory:

- Clears the calculator line and history stack.
- Deletes all Solver equations and their variables, and clears all other variables in application and numeric function menus.
- Clears all STAT lists and their names.
- Clears all appointments.
- Sets the calculator to certain “start-up” settings—month/day/year date format, 12-hour time format, 4 decimal places, period (.) decimal point, Degrees mode, printer tracing off, print-speed without the AC adapter, and beeper on.
- Starts a new random number sequence using a seed from the system clock the next time **RAN#** is pressed.

Erasing Continuous Memory does not affect the current time and date.

To erase Continuous Memory, press and hold down **CLR**, the leftmost menu key, and the rightmost menu key. (You will be pressing three keys simultaneously). When the keys are released, the HP-27S displays **MEMORY LOST**.

Continuous Memory may inadvertently be erased if the calculator is dropped or if power is interrupted.

Clock Accuracy

The system clock is regulated by a quartz crystal accurate to within three minutes per month for normal operating temperatures. The accuracy of the clock crystal is affected by temperature, physical shock, humidity, and aging. Optimum accuracy is maintained at 25°C (77°F).

Environmental Limits

In order to maintain product reliability, you should observe the following temperature and humidity limits:

- Operating temperature: 0° to 45°C (32° to 113°F).
- Storage temperature: -20° to 65°C (-4° to 149°F).
- Operating and storage humidity: 90% relative humidity at 40°C (104°F) maximum.

Determining If the Calculator Requires Service

Use these guidelines to determine if the calculator requires service. If these procedures confirm that the calculator is not functioning properly, read "If the Calculator Requires Service" on page 201.

- **If the calculator won't turn on (nothing is visible in the display):**
 1. Attempt to reset the calculator (see page 195).
 2. If the calculator fails to respond after step 1, replace the batteries (see page 196). If you've just replaced the batteries, see the bottom of page 193.

If steps 1 and 2 do not restore the display, the calculator requires service.

- **If the calculator doesn't respond to keystrokes (nothing happens when you press the keys):**
 1. Attempt to reset the calculator (see page 195).
 2. If the calculator fails to respond after step #1, attempt to erase Continuous Memory (see page 196). This will erase all the information you've stored.

If steps 1 and 2 do not restore calculator function, the calculator requires service.

■ **If the calculator responds to keystrokes but you suspect that it is malfunctioning:**

1. Do the self-test (described below). If the calculator fails the self test, it requires service.
2. If the calculator passes the self-test, it is quite likely you've made a mistake in operating the calculator. Try rereading portions of the manual, and check "Answers to Common Questions" on page 189.
3. You can communicate with an expert on calculator operation by contacting the Calculator Technical Support department. The address and phone number are listed on the inside back cover.

Confirming Calculator Operation—the Self-Test

If the display can be turned on, but it appears that the calculator is not operating properly, you can do a diagnostic self-test. The self-test runs continuously, repeating until you halt it.

To run the self-test:

1. Turn the calculator on.
2. If you have the optional Infrared Printer, turn it on. Certain diagnostic information is printed during the test.
3. If possible, return to the MAIN display (press **MAIN**).
4. To start the self-test, hold down **CLR** while you press the fifth menu key from the left.* Once the self-test has begun, do not press any keys until you are ready to halt the test.

* Pressing the fourth menu key from the left starts another self-test that is used at the factory. If you accidentally start this self-test, you can stop it by holding down the **CLR** key while you press the third menu key from the left.

5. During the test, the calculator beeps periodically, and displays various patterns and characters. Watch for one of two messages that are displayed at the end of each test cycle, before the test automatically repeats:
 - If the calculator passes the self-test, the HP-27S displays `OK-27S-E`.
 - If the HP-27S displays `FAIL` followed by a five-digit number, the calculator may require service.
6. To halt the self-test, hold down `CLR` while you press the third menu key from the left. The HP-27S displays `MACHINE RESET`. If you press any other key instead, the test halts and the HP-27S displays a `FAIL` message. *This message results from an incorrect key being pressed, and does not mean that the calculator requires service.*
7. If the HP-27S failed the self-test, repeat steps 4 through 6 to verify the results. If you do not have a printer, write down the messages that are displayed after the component tests.

Limited One-Year Warranty

What Is Covered

The calculator (except for the batteries, or damage caused by the batteries) is warranted by Hewlett-Packard against defects in materials and workmanship for one year from the date of original purchase. If you sell your unit or give it as a gift, the warranty is automatically transferred to the new owner and remains in effect for the original one-year period. During the warranty period, we will repair or, at our option, replace at no charge a product that proves to be defective, provided you return the product, shipping prepaid, to a Hewlett-Packard service center. (Replacement may be with a newer model of equivalent or better functionality.)

This warranty gives you specific legal rights, and you may also have other rights that vary from state to state, province to province, or country to country.

What Is Not Covered

Batteries, and damage caused by the batteries, are not covered by the Hewlett-Packard warranty. Check with the battery manufacturer about battery and battery leakage warranties.

This warranty does not apply if the product has been damaged by accident or misuse or as the result of service or modification by other than an authorized Hewlett-Packard service center.

No other express warranty is given. The repair or replacement of a product is your exclusive remedy. **ANY OTHER IMPLIED WARRANTY OF MERCHANTABILITY OR FITNESS IS LIMITED TO THE ONE-YEAR DURATION OF THIS WRITTEN WARRANTY.** Some states, provinces, or countries do not allow limitations on how long an implied warranty lasts, so the above limitation may not apply to you. **IN NO EVENT SHALL HEWLETT-PACKARD COMPANY BE LIABLE FOR CONSEQUENTIAL DAMAGES.** Some states, provinces, or countries do not allow the exclusion or limitation of incidental or consequential damages, so the above limitation or exclusion may not apply to you.

Products are sold on the basis of specifications applicable at the time of manufacture. Hewlett-Packard shall have no obligation to modify or update products once sold.

Consumer Transactions in the United Kingdom

This warranty shall not apply to consumer transactions and shall not affect the statutory rights of a consumer. In relation to such transactions, the rights and obligations of Seller and Buyer shall be determined by statute.

If the Calculator Requires Service

Hewlett-Packard maintains service centers in many countries. These centers will repair a calculator or replace it with the same model or one of equal or greater value, whether it is under warranty or not. There is a charge for service after the warranty period. Calculators normally are serviced and reshipped within 5 working days of receipt.

Obtaining Service

- **In the United States:** Send the calculator to the Calculator Service Center listed on the inside of the back cover.
- **In Europe:** Contact your HP sales office or dealer or HP's European headquarters for the location of the nearest service center. *Do not ship the calculator for service without first contacting a Hewlett-Packard office.*

Hewlett-Packard S.A.
150, Route du Nant-d'Avril
P.O. Box CH 1217 Meyrin 2
Geneva, Switzerland
Telephone: (022) 82 81 11

- **In other countries:** Contact your HP sales office or dealer or write to the U.S. Calculator Service Center (listed on the inside of the back cover) for the location of other service centers. If local service is unavailable, you can ship the calculator to the U.S. Calculator Service Center for repair.

All shipping, reimportation arrangements, and customs costs are your responsibility.

Service Charge

There is a standard repair charge for out-of-warranty service. The Calculator Service Center (listed on the inside of the back cover) can tell you how much this charge is. The full charge is subject to the customer's local sales or value-added tax wherever applicable.

Calculator products damaged by accident or misuse are not covered by the fixed service charges. In these cases, charges are individually determined based on time and material.

Shipping Instructions

If your calculator requires service, ship it to the nearest authorized service center or collection point. (You must pay the shipping charges for delivery to the service center, whether or not the calculator is under warranty.) Be sure to:

- Include your return address and description of the problem.
- Include proof of purchase date if the warranty has not expired.
- Include a purchase order, check, or credit card number plus expiration date (Visa or MasterCard) to cover the standard repair charge. In the United States and some other countries, the serviced calculator will be returned C.O.D. if you do not pay in advance.
- Ship the calculator in adequate protective packaging to prevent damage. Such damage is not covered by the warranty, so we recommend that you insure the shipment.
- Pay the shipping charges for delivery to the Hewlett-Packard service center, whether or not the calculator is under warranty.

All shipping, reimportation arrangements, and customs costs are your responsibility.

Warranty on Service

Service is warranted against defects in materials and workmanship for 90 days from the date of service.

Service Agreements

In the U.S., a support agreement is available for repair and service. Refer to the form in the front of the manual. For additional information, contact the Calculator Service Center (see the inside of the back cover).

Regulatory Information

Radio Frequency Interference

U.S.A. The HP-27S generates and uses radio frequency energy and may interfere with radio and television reception. The calculator complies with the limits for a Class B computing device as specified in Subpart J of Part 15 of FCC Rules, which provide reasonable protection against such interference in a residential installation. In the unlikely event that there is interference to radio or television reception (which can be determined by turning the HP-27S off and on or by removing the batteries), try:

- Reorienting the receiving antenna.
- Relocating the calculator with respect to the receiver.

For more information, consult your dealer, an experienced radio/television technician, or the following booklet, prepared by the Federal Communications Commission: *How to Identify and Resolve Radio-TV Interference Problems*. This booklet is available from the U.S. Government Printing Office, Washington, D.C. 20402, Stock Number 004-000-00345-4. At the first printing of this manual, the telephone number was (202) 783-3238.

West Germany. The HP-27S and the HP 82240A printer comply with VFG 1046/84, VDE 0871B, and similar non-interference standards.

If you use equipment that is not authorized by Hewlett-Packard, that system configuration has to comply with the requirements of Paragraph 2 of the German Federal Gazette, Order (VFG) 1046/84, dated December 14, 1984.

Air Safety Notice (U.S.A.)

The HP-27S and the HP 82240A printer comply with the requirements of RTCA (Radio Technical Commission for Aeronautics) Docket 160B, Section 21. Many airlines permit the use of calculators in flight based on such a qualification. However, before boarding a flight, check with an airline representative regarding use of calculators in flight.

B

More About the Solver

Section 5 explains how to enter equations and interpret results. This appendix provides additional information about direct and iterative solutions.

Direct Solutions

In seeking a direct solution, the Solver attempts to isolate the unknown on one side of the equation. The value of the other side is the solution. The Solver can isolate the unknown if the equation meets these conditions:

- The only operators involving the unknown are $+$, $-$, \times , \div , and $^$.
- The unknown does not appear as an exponent.
- The unknown occurs only once in the equation. There are two exceptions:
 1. Occurrences of the unknown as the argument of the S function can be ignored. For example, $\text{IF}(S(X); Y-X; Y-5)$ can be solved directly for X.
 2. The variable is counted as appearing only once within an IF function if it appears only once in the conditional expression, or it appears only once in one or both of the algebraic expressions. For example, both $Y=\text{IF}(A<B; 4\times X; 6\times X)$ and $Y=\text{IF}(A<B; 4\times X; \text{IF}(A=B; 5\times X; 6\times X))$ can be solved directly for X.

- The unknown does not appear in the conditional expression in an IF function, except as the argument of an S function. For example, $Y=IF(X>B:2\times B:B+12)$ cannot be solved directly for X.
- The unknown does not appear as an argument for any of these functions:

ABS(x)	MOD(x:y)
COMB(x:y)	PERM(x:y)
FACT(x)	RND(x:y)
FP(x)	SGN(x)
IDIV(x:y)	SPFV(i%:n)
INT(x)	SPPV(i%:n)
IP(x)	TRN(x:y)
MAX(x:y)	USFV(i%:n)
MIN(x:y)	USPV(i%:n)

- The unknown does not appear as the third argument (*cal*) of the DDAYS function.

When the equation contains the unknown raised to a positive, even power, there may be more than one solution. If the solver can isolate the unknown, it finds *one* of the solutions using the positive root. For example, $(X-1)^2=25$ has two solutions. The Solver algebraically reduces this equation to $X - 1 = 5$ and calculates $X = 6$. To find the other solution, the equation can be rewritten $(1-X)^2=25$. The Solver then returns $X = -4$.

If the unknown can be isolated but an answer cannot be found, the HP-27S displays SOLUTION NOT FOUND. There are two reasons this might happen:

- Rearrangement causes a mathematical error. For example, when the Solver tries to isolate X in $1\div X=0$, division by 0 occurs.
- The rearranged equation violates an algebraic rule. For example, the equation $0\div X=1$ rearranges to $X = 0$, which obviously is *not* a solution.

Since the Solver selects only the positive root when the unknown is raised to an even power, the HP-27S may display SOLUTION NOT FOUND when a solution could be found using the negative root. You can rewrite the equation to force the Solver to use the negative root by negating the algebraic expression that is raised to the even power. For example, $(1-1 \div X)^2=1$ cannot be solved because it is rearranged to $1 \div X = 0$. However, if the equation is rewritten as $(1 \div X - 1)^2=1$, a solution $X = 0.5$ is found.

When the unknown is an angle argument (arguments of SIN, COS, TAN, XCOORD, YCOORD), there usually are an infinite number of solutions. If the Solver can isolate the unknown, it finds *one* of the solutions. For example, $\text{TAN}(A)=1$ has an infinite number of solutions: $A = 45^\circ \pm 180 \times n, n = 0, 1, 2, \dots$. The Solver algebraically reduces this equation to $A = \text{ATAN}(1)$ and calculates $A = 45^\circ$. The equation can be rewritten to find other direct solutions. For example, $\text{TAN}(A-180)=1$ is reduced to $A = \text{ATAN}(1) + 180; A = 225^\circ$.

Another way to find other solutions is to append *unknown-unknown+* to the beginning of the equation to "force" an iterative solution. For example, $A - A + \text{TAN}(A) = 1$ cannot be solved directly. Different solutions can be found by entering appropriate guesses.

Iterative Solutions

When the Solver cannot isolate the unknown, it seeks an iterative solution by searching for a number that sets the left side of the equation equal to the right side. A convenient way to conceptualize the process is to think of the equation as a function of one (unknown) variable for which the Solver is seeking a root.

How the Solver Finds a Root Iteratively

Consider an equation containing a number of variables, including unknown x . When values have been entered for all variables except the unknown, the equation has the form:

$$g(x) = h(x)$$

where $g(x)$ and $h(x)$ are the left and right sides of the equation. For example, when the equation:

$$ax^3 + \frac{b}{r}x^2 = \frac{1}{4}cx + d$$

is solved for x with $a = -2$, $b = 8$, $r = 2$, $c = 24$, and $d = -8$, it has the form:

$$\underbrace{-2x^3 + 4x^2}_{g(x)} = \underbrace{6x - 8}_{h(x)}$$

Since $g(x) - h(x) = 0$, the equation can be rewritten:

$$f(x) = g(x) - h(x) = -2x^3 + 4x^2 - 6x + 8 = 0$$

The value of x for which $f(x) = 0$ is called a *root* of the equation. The Solver iteratively seeks a root for $f(x)$ by evaluating the function repeatedly at estimates of x , and comparing the results to previous estimates. Using a complex algorithm, the Solver intelligently “predicts” a new estimate where the graph might cross the x -axis.

Figure B-1 illustrates the function $f(x) = -2x^3 + 4x^2 - 6x + 8$. The graph shows one root. (The first example on page 212 calculates this root.)

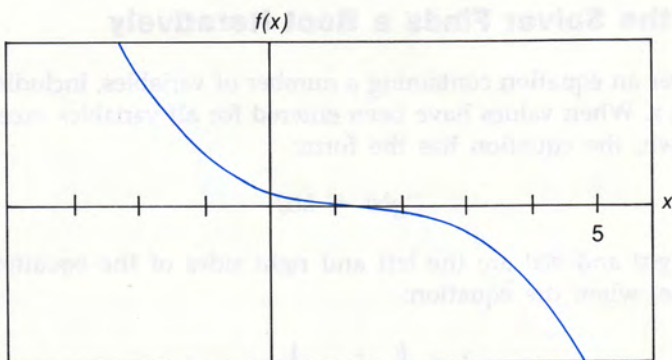

Figure B-1. $f(x) = -2x^3 + 4x^2 - 6x + 8$

Figure B-2 illustrates $f(x) = x^3 - 5x^2 - 10x + 20$, which has three roots.

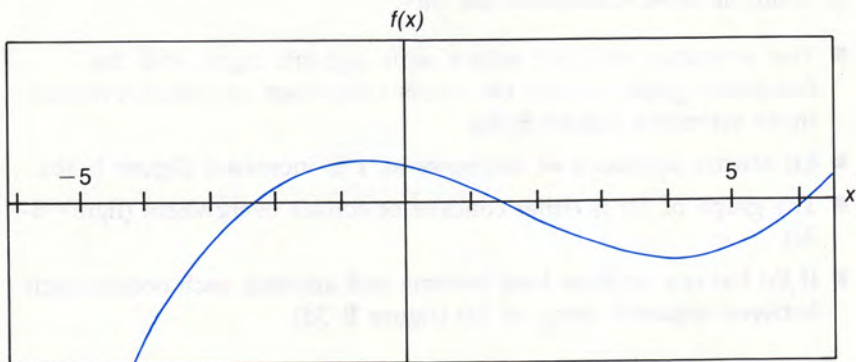

Figure B-2. $f(x) = x^3 - 5x^2 - 10x + 20$

All three roots can be found by entering appropriate guesses for x before solving for x . To help select guesses, you can get some idea of the behavior of the function by calculating the value of $f(x)$ at various values of x . (See the example "Finding Several Roots of a Function" on page 179.)

The Solver's Ability to Find a Root

If any two estimates yield $f(x)$ with opposite signs, the Solver presumes that $f(x)$ crosses the x -axis in at least one place between the two estimates. The interval is systematically narrowed until a root is found.

For the Solver to find a root, the root has to exist within the range of numbers of the calculator, and $f(x)$ must be defined in the domain where the iterative search occurs. The Solver always find a root if one or more of these conditions are met:

- Two estimates yield $f(x)$ values with opposite signs, and the function's graph crosses the x -axis in at least one place between those estimates (figure B-3a).
- $f(x)$ always increases or decreases as x is increased (figure B-3b).
- The graph of $f(x)$ is either concave or convex everywhere (figure B-3c).
- If $f(x)$ has one or more local minima and maxima, each occurs singly between adjacent zeros of $f(x)$ (figure B-3d).

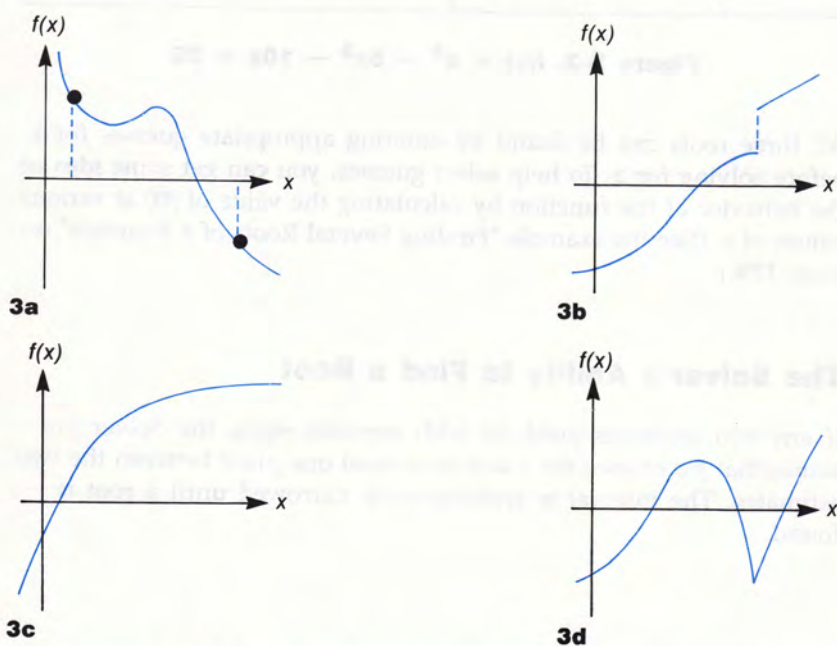

Figure B-3. Functions for Which a Root Can Be Found

In most situations, the calculated root is an accurate estimate of the theoretical, infinitely precise root of the equation. An "ideal" solution is one for which $f(x) = 0$. However, a non-zero value for $f(x)$ is often also acceptable, because it results from approximating numbers with limited (12-digit) precision.

The Solver can deal with a wide variety of complex situations. Results of an iterative solution are divided into four major situations—cases 1, 2, 3, and 4.

Cases Where a Root Is Displayed (Cases 1a and 1b)

In case 1, the Solver automatically displays the calculated root. Table B-1 describes the two case 1 situations. (Also see figure 5-1 on page 114.)

Table B-1. Case 1 Solutions

Case	Signs of $f(x)$ for Final Estimates	Comparison of Final Estimates	Trends in $f(x)$
Case 1a	$f(x) = 0$	—	—
Case 1b	Opposite	Neighbors	$f(x)$ for the estimates have not been strongly diverging from zero as x approaches the two neighbors from both sides.

For case 1a, the calculated root sets $f(x)$ exactly equal to 0. For case 1b, the calculated root is a 12-digit number adjacent to the place where the function's graph crosses the x -axis. Cases 1a and 1b are differentiated by pressing the menu key for the unknown after the root has been displayed. For case 1b solutions, the HP-27S displays the values of $g(x)$ (LEFT) and $h(x)$ (RIGHT).

Example: A Case 1 Solution With One Root. Find the root of the equation:

$$-2x^3 + 4x^2 - 6x + 8 = 0$$

1. Press **SOLVE**, then **NEW**.
2. Type $-2 \times X^3 + 4 \times X^2 - 6 \times X + 8 = 0$ **INPUT** **CALC**.

Keys:	Display:	Description:
0 X	X=0.0000	Enters guesses.
10 X	X=10.0000	
X	X=1.6506	Calculates X.
X	LEFT : -0.000000000004 RIGHT : 0.000000000000	Optional; indicates case 1b.
◀	X=1.6506	
		Clears message.

Example: A Case 1 Solution With Two Roots. Find the roots of the equation:

$$x^2 + x - 6 = 0$$

1. Press **SOLVE**, then **NEW**.
2. Type $X^2 + X - 6 = 0$ **INPUT** **CALC**.

Keys:**Display:****Description:**0 \boxed{x} $x=0.0000$ 10 \boxed{x} $x=10.0000$ \boxed{x} $x=2.0000$ \boxed{x} $x=2.0000$ 0 \boxed{x} $x=0.0000$ 10 $\boxed{+/-}$ \boxed{x} $x=-10.0000$ \boxed{x} $x=-3.0000$ \boxed{x} $x=-3.0000$

Enters guesses for the positive root.

Calculates the positive root.

Optional; indicates case 1a.

Enters guesses for the negative root.

Calculates the negative root.

Optional; indicates case 1a.

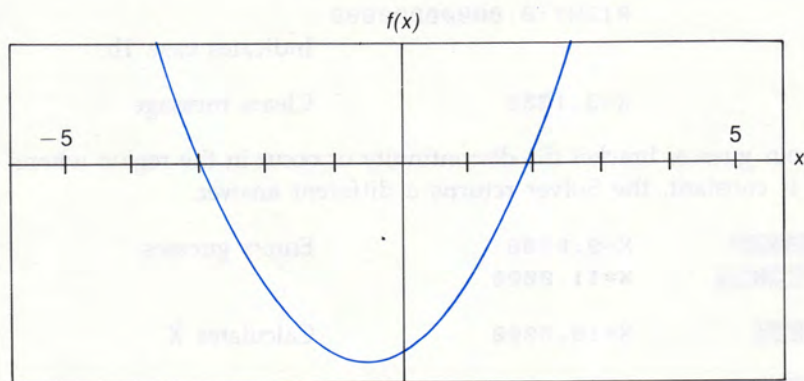
**Figure B-4.** $f(x) = x^2 + x - 6$

Example: A Discontinuous Function. A case 1 solution may exist for a function that is discontinuous. For example, the function:

$$f(x) = \begin{cases} 3x^3 - 45x^2 + 350 & \text{for } x < 10 \\ 1000 & \text{for } x \geq 10 \end{cases}$$

is defined for all values of x , but discontinuous at $x = 10$.

1. Press **SOLVE**, then **NEW**.
2. Type `IF<X<10:3*X^3-45*X^2+350:1000>=0` **INPUT**
CALC.

Keys:	Display:	Description:
0 X	X=0.0000	Enters guesses.
9 X	X=9.0000	
X	X=3.1358	Calculates positive root.
X	LEFT : -0.00000000100 RIGHT: 0.000000000000	Indicates case 1b.
⏏	X=3.1358	Clears message.

If your guesses bracket the discontinuity or occur in the region where $f(x)$ is constant, the Solver returns a different answer.

9 X	X=9.0000	Enters guesses.
11 X	X=11.0000	
X	X=10.0000	Calculates X.
X	LEFT : 1,000.00000000 RIGHT: 0.00000000000	Indicates case 1b.

Notice that *LEFT* and *RIGHT* are relatively far apart. This indicates that the answer is probably *not* a good solution to the equation, and demonstrates the importance of viewing *LEFT* and *RIGHT* for a case 1 solution if you have any doubt about the answer. Examining the graph of the function (see figure B-5) shows how the Solver arrived at the answer. When the iterative process produced the estimate $X = 10$, the Solver determined that two neighboring estimates yield values of $f(x)$ with opposite signs.

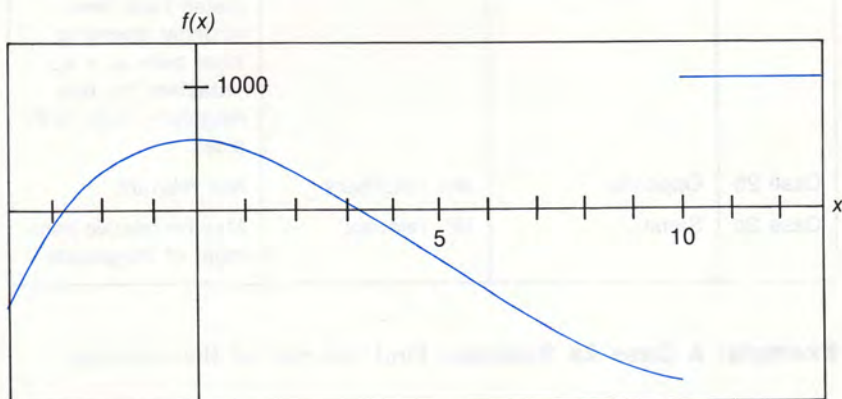

Figure B-5. $f(x)$ For a Discontinuous Function

Case 2 Solutions

In case 2, the Solver does not find an estimate for which $f(x) = 0$. Furthermore, the criteria for a case 1b solution are not met. The HP-27S automatically displays the values of *LEFT* and *RIGHT* for the best final estimate, rather than an answer. Pressing any key displays the final estimate that generated those values. Use great caution in interpreting the results.

Table B-1 describes the case 2 conditions. (Also see figure 5-2 on page 116.) To view the two final estimates, press and hold down the menu key for the unknown until the displayed estimates stop changing.

Table B-1. Case 2 Solutions

Case	Signs of $f(x)$ for Final Estimates	Comparison of Final Estimates	Trends in $f(x)$
Case 2a	Opposite	Neighbors	$f(x)$ for the two estimates have been strongly diverging from zero as x approaches the two neighbors from both sides.
Case 2b	Opposite	Not neighbors	Not relevant
Case 2c	Same	Not relevant	May be relative minimum of magnitude

Example: A Case 2a Solution. Find the root of the equation:

$$\frac{x}{x^2 - 6} - 1 = 0$$

1. Press **SOLVE**, then **NEW**.
2. Type $X \div (X^2 - 6) - 1 = 0$ **INPUT** **CALC**.

As x approaches $\sqrt{6}$, $f(x)$ becomes a very large positive or negative number:

Keys:	Display:	Description:
2.3 \times	$X=2.3000$	Enters guesses bracketing $\sqrt{6}$.
2.7 \times	$X=2.7000$	
\times	LEFT : 81,649,658,092.0 RIGHT: 0.000000000000	Case 2.
\leftarrow	$X=2.4495$	Displays best estimate of X .
\times (hold down)	$X:2.44948974279 +$ $X:2.44948974278 -$	Final estimates are neighbors; case 2a.
\leftarrow	$X=2.4495$	Displays calculator line.

Figure B-6 illustrates the pole between the final estimates. The initial guesses yielded opposite signs for $f(x)$. The Solver narrowed the interval between successive estimates until two neighbors were found. The function has roots at -2 and 3 , which can be found by entering appropriate guesses.

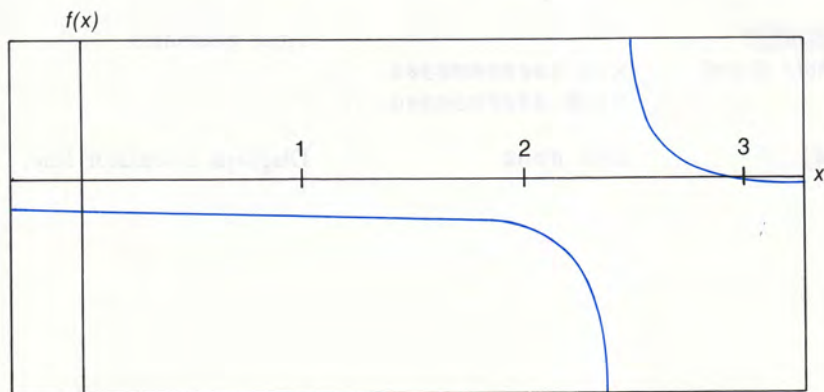

Figure B-6. $f(x) = x \div (x^2 - 6) - 1$

Example: A Case 2b Solution. Find the root of the equation:

$$\sqrt{\frac{x}{x + .3}} - .5 = 0$$

1. Press **SOLVE**, then **NEW**.
2. Type $\text{SQRT}(X \div (X + .3)) - .5 = 0$ **INPUT** **CALC**.

Keys:	Display:	Description:
0 X	X=0.0000	Enters guesses.
10 X	X=10.0000	
X	X=0.1000	Calculates root.

Now, attempt to find a negative root by entering guesses 0 and -10.

0 X	X=0.0000	Enters guesses.
10 +/- X	X=-10.0000	
X	LEFT : -0.500000000000 RIGHT: 0.000000000000	Case 2.

↵	X=0.0000	Displays best estimate of X.
----------	----------	------------------------------

X		Final estimates.
(hold down)	X: 0.000000000000 - X: -0.300000000000 +	

↵	X=0.0000	Displays calculator line.
----------	----------	---------------------------

Notice that $f(x)$ has opposite signs for the two final estimates, and that the final estimates are not neighbors. This is a case 2b solution. Figure B-7 illustrates the function. The final two estimates bracket a region where $f(x)$ is undefined.

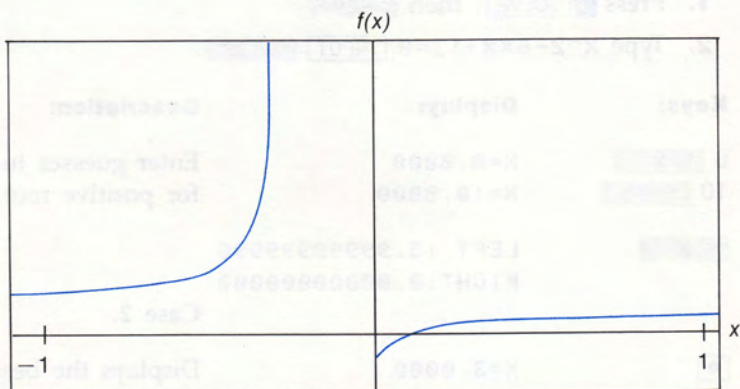

Figure B-7. $f(x) = \sqrt{x \div (x + .3)} - .5$

Example: A Case 2c Solution (Relative Minimum). Calculate the root of the equation:

$$x^2 - 6x + 13 = 0$$

1. Press **SOLVE**, then **NEW**.
2. Type $X^2-6X+13=0$ **INPUT** **CALC**.

Keys:	Display:	Description:
0 X	X=0.0000	Enter guesses to search for positive root.
10 X	X=10.0000	
X	LEFT :3.99999999996 RIGHT:0.00000000000	Case 2.
↵	X=3.0000	Displays the best estimate of X.
X (hold down)	X:3.00000027360 + X:3.00000027035 +	Final estimates; case 2c.
↵	X=3.0000	Displays calculator line.

$f(x)$ has the same sign for both estimates, indicating that the Solver has not found a place where the function probably crosses the x -axis. Figure B-8 illustrates the function, a parabola with a minimum at $X = 3$. To find the y -coordinate of the minimum, edit the equation to $X^2-6X+13=Y$, enter 3 for X , and solve for Y .

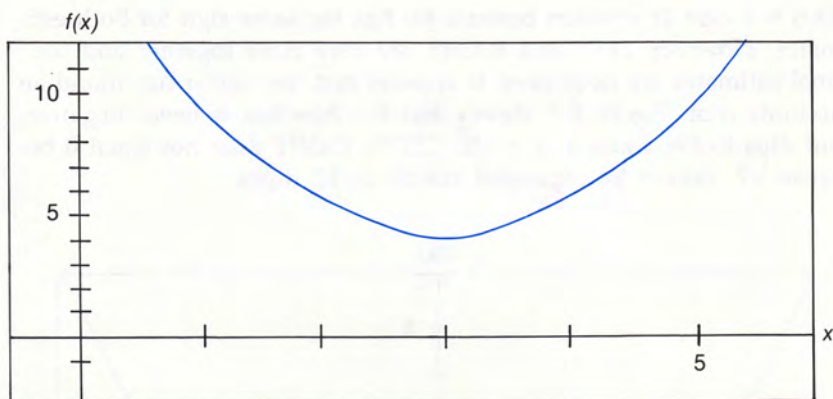

Figure B-8. $f(x) = x^2 - 6x + 13$

Example: A Function Dipping to the X-Axis. Calculate the root of the equation:

$$|x^2 - 2| = 0$$

1. Press **SOLVE**, then **NEW**.
2. Type $\text{ABS}(X^2-2)=0$ **INPUT** **CALC**.

Keys:	Display:	Description:
1 X	X=1.0000	Enters guesses.
2 X	X=2.0000	
X	LEFT :0.000000000001 RIGHT:0.000000000000	Case 2.
◀	X=1.4142	Displays the answer.
X (hold down)	X:1.41421356237 + X:1.41421356236 +	Final estimates; case 2c.
◀	X=1.4142	Displays calculator line.

This is a case 2c solution because $f(x)$ has the same sign for both estimates. However, *LEFT* and *RIGHT* are very close together and the final estimates are neighbors. It appears that the Solver has found an accurate root. Figure B-9 shows that the function is never negative, but dips to the x -axis at $x = \sqrt{2}$. *LEFT*–*RIGHT* does not equal 0 because $\sqrt{2}$ cannot be expressed *exactly* in 12 digits.

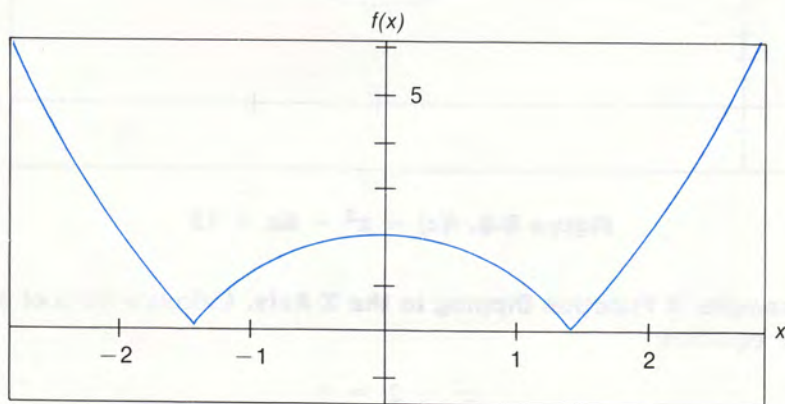

Figure B-9. A Minimum at the X-Axis

Case 3: Bad Guesses

If both initial guesses are outside the domain in which $f(x)$ is defined, the Solver cannot use them. In this case, the HP-27S displays:

BAD GUESSES:
PRESS [CLR] TO VIEW

Example: A Case 3 Situation. Find the root of the equation:

$$\sqrt{x + \ln x} - .5 = 0$$

1. Press **[SOLVE]**, then **[NEW]**.
2. Type $\text{SQRT}(X+\text{LN}(X))-.5=0$ **[INPUT]** **[CALC]**.

Keys:**Display:****Description:**

These keystrokes attempt to find a negative root.

0 $\boxed{\times}$ $X=0.0000$ Solver will start searching in the range -10 through 0 .

10 $\boxed{+/-}$ $\boxed{\times}$ $X=-10.0000$

$\boxed{\times}$ BAD GUESSES:
PRESS $\boxed{[CLR]}$ TO
VIEW $f(x)$ is undefined in this range (see figure B-10).

\boxed{CLR} $X:0.0000000000$ Displays guesses.
 $X:-10.0000000000$

$\boxed{\blacktriangleleft}$ $X=-10.0000$ Displays calculator line.

Enter different guesses and search again:

0 $\boxed{\times}$ $X=0.0000$ Enters guesses.

10 $\boxed{\times}$ $X=10.0000$

$\boxed{\times}$ $X=0.6622$ Case 1 answer.

$\boxed{\times}$ LE...: $-1.000000000000E-12$
RIGHT: 0.0000000000 Optional; indicates case 1b.

$\boxed{\blacktriangleleft}$ $X=0.6622$ Redisplays X.

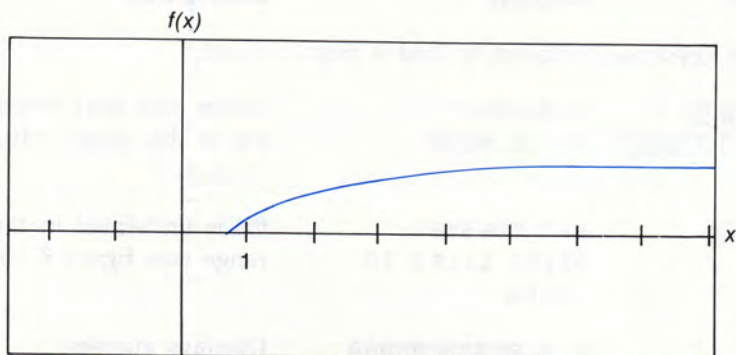

Figure B-10. $f(x) = \sqrt{x + \ln x} - .5$

Case 4: When a Solution Isn't Found

The Solver can fail to find a solution because no iterative solution exists, or because the search algorithm cannot find a solution using the initial estimates. For example:

$$\sqrt{\frac{x}{x + .3}} - .5 = 0$$

can be solved by entering appropriate positive guesses (see figure B-7). However, entering negative guesses in the range where the function is defined causes the Solver to search the function as it asymptotically approaches 1. Eventually, the HP-27S displays SOLUTION NOT FOUND.

Figure B-11 illustrates a function that equals 1 throughout the range of numbers, except that it equals 0 at $x = 0$. The Solver finds a solution only if one of the guesses is 0.

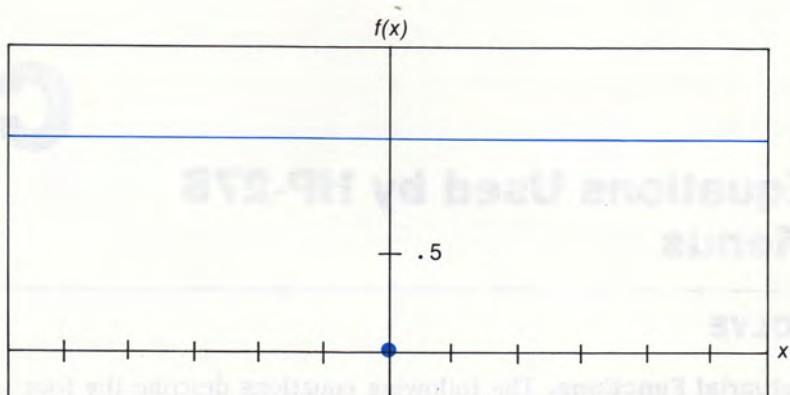

Figure B-11. $f(x) = |\text{SGN}(x)|$

Round-Off Error

The limited (12-digit) precision of the calculator can cause “round-off” errors that adversely affect iterative solutions. For example:

$$[(|x| + 1) + 10^{15}]^2 - 10^{30} = 0$$

has no roots because the left side of the equation is always positive. However, the Solver finds an answer. When the equation is edited to the form $y = f(x)$ and solved for y , the Solver calculates $y = 0$ due to round-off error. By recognizing situations where round-off error might occur, you can better evaluate the results, and perhaps rewrite the function to reduce the effects of round-off.

C

Equations Used by HP-27S Menus

SOLVE

Actuarial Functions. The following equations describe the four Solver actuarial functions.

n = number of compounding periods.

$i\%$ = periodic interest rate, expressed as a percentage.

Single Payment Present Value Function

(Present value of a single \$1.00 payment occurring n periods in the future.)

$$\text{SPPV } (i\%:n) = \left(1 + \frac{i\%}{100}\right)^{-n}$$

Single Payment Future Value Function

(Future value after n periods of a single \$1.00 payment.)

$$\text{SPFV } (i\%:n) = \left(1 + \frac{i\%}{100}\right)^n$$

Uniform Series Present Value Function

(Present value of a \$1.00 payment that occurs n times.)

$$\text{USPV } (i\%:n) = \frac{1 - \left(1 + \frac{i\%}{100}\right)^{-n}}{\frac{i\%}{100}}$$

Uniform Series Future Value Function

(Future value of a \$1.00 payment that occurs n times.)

$$\text{USFV } (i\%:n) = \frac{\left(1 + \frac{i\%}{100}\right)^n - 1}{\frac{i\%}{100}}$$

Statistics

n = number of items in the list.

x' = an element of the sorted list.

$$TOTAL = \Sigma x_i$$

$$MEAN = \bar{x} = \frac{\Sigma x_i}{n}$$

$$MEDIAN = x_j' \text{ for odd } n, \text{ where } j = \frac{n + 1}{2}$$

$$MEDIAN = \frac{(x_j' + x_{j+1}')}{2} \text{ for even } n, \text{ where } j = \frac{n}{2}$$

$$STDEV = \sqrt{\frac{\Sigma (x_i - \bar{x})^2}{n - 1}}$$

$$RANGE = MAX - MIN$$

$$W.MN = \frac{\Sigma y_i x_i}{\Sigma y_i}$$

$$G.SD = \sqrt{\frac{\Sigma y_i x_i^2 - (\Sigma y_i) \bar{x}^2}{(\Sigma y_i) - 1}}$$

$$\Sigma X = \Sigma x_i$$

$$\Sigma Y = \Sigma y_i$$

$$\Sigma X^2 = \Sigma x_i^2$$

$$\Sigma Y^2 = \Sigma y_i^2$$

$$\Sigma XY = \Sigma x_i y_i$$

Curve Fitting

Model		Transformation	X_i	Y_i
LIN	$y = B + Mx$	$y = B + Mx$	x_i	y_i
EXP	$y = Be^{Mx}$	$\ln y = \ln B + Mx$	x_i	$\ln y_i$
LOG	$y = B + M \ln x$	$y = B + M \ln x$	$\ln x_i$	y_i
PWR	$y = Bx^M$	$\ln y = \ln B + M \ln x$	$\ln x_i$	$\ln y_i$

Let:

$$\bar{X} = \frac{\sum X_i}{n} \quad \bar{Y} = \frac{\sum Y_i}{n}$$

$$SX^2 = \sum (X_i - \bar{X})^2$$

$$SY^2 = \sum (Y_i - \bar{Y})^2$$

$$SXY = \sum (X_i - \bar{X})(Y_i - \bar{Y})$$

Then:

$$M = \frac{SXY}{SX^2}$$

$$B = b \text{ (LIN, LOG models)}$$

$$B = e^b \text{ (EXP, PWR models)}$$

$$\text{where } b = \bar{Y} - M \bar{X}$$

$$CORR = \frac{SXY}{\sqrt{SX^2 \times SY^2}}$$

TVM

S = payment mode factor (0 for End mode; 1 for Begin mode).

$$i\% = \frac{I\%YR}{P/YR}$$

$$0 = PV + \left(1 + \frac{i\% \times S}{100}\right) \times PMT \times USPV(i\%:n) + FV \times SPPV(i\%:n)$$

Amortization

ΣINT = accumulated interest

$\Sigma PRIN$ = accumulated principal

i = periodic interest rate

BAL is initially the TVM value of PV , rounded to the current display setting.

PMT is initially the TVM value of PMT , rounded to the current display setting.

$$i = \frac{I\%YR}{P/YR \times 100}$$

For each payment amortized:

INT' is rounded to the current display setting; $INT' = 0$ for period 0 in Begin mode.

$$INT' = BAL \times i$$

$$INT = INT' \text{ (with sign of } PMT \text{)}$$

$$PRIN = PMT + INT'$$

$$BAL_{new} = BAL_{old} + PRIN$$

$$\Sigma INT_{new} = \Sigma INT_{old} + INT$$

$$\Sigma PRIN_{new} = \Sigma PRIN_{old} + PRIN$$

Numeric Function Menus

PROB

$$C X,Y = \frac{x!}{y!(x-y)!}$$

$$P X,Y = \frac{x!}{(x-y)!}$$

CONVERT

$$XCOORD = R \cos \Delta$$

$$YCOORD = R \sin \Delta$$

$$R = \sqrt{XCOORD^2 + YCOORD^2}$$

$$\tan \Delta = YCOORD \div XCOORD \quad -180^\circ < \Delta \leq 180^\circ$$

%CHG

$$\%CHANGE = \left(\frac{NEW - OLD}{OLD} \right) \times 100$$

D

Menu Maps and Tables

The following menu maps illustrate how to display each of the menus within the HP-27S four applications. The numeric function menus and control menus are listed in table form.

Variables are enclosed in boxes to illustrate how they are used:



Variable used to store and/or calculate values.



Calculate-only or display-only variable. Values cannot be stored in this variable.



Store-only variable. Variable cannot be calculated in this menu.

SOLVE Menu Map

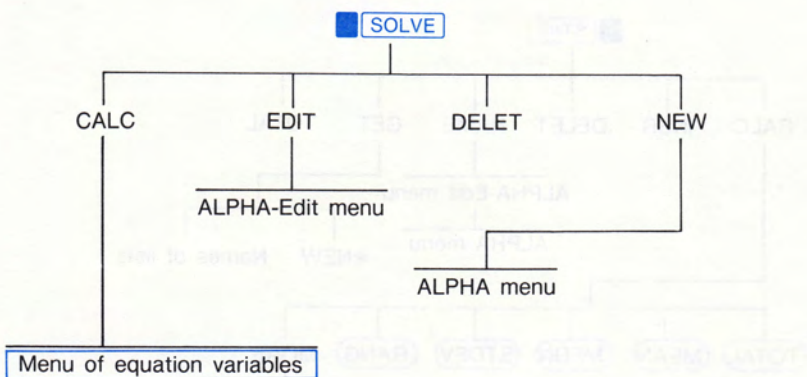

STAT Menu Map

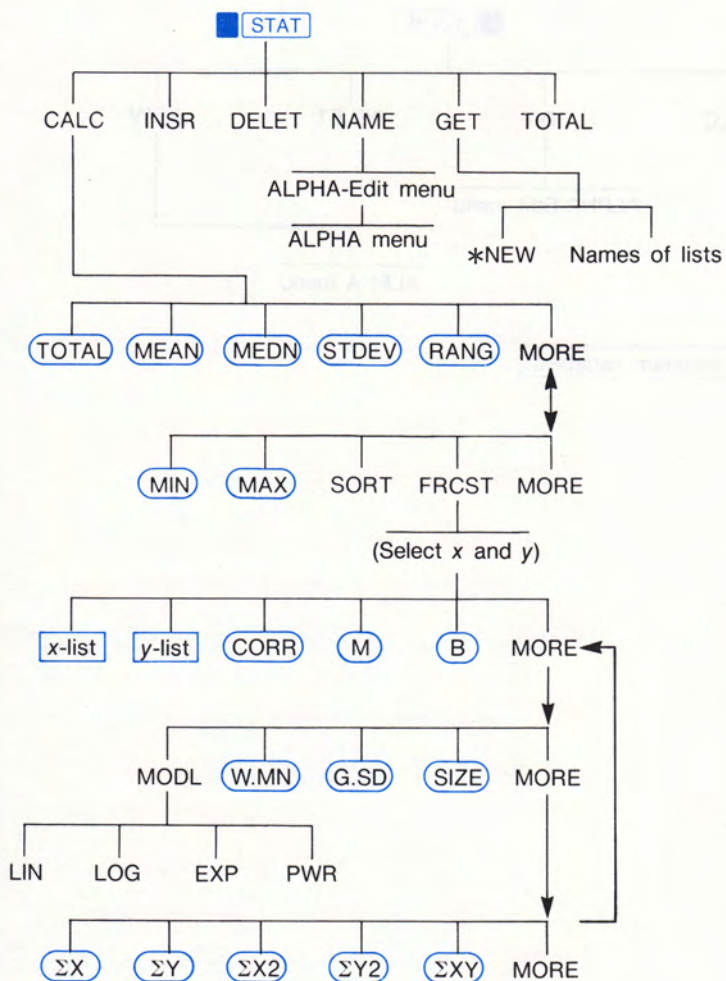

TVM Menu Map

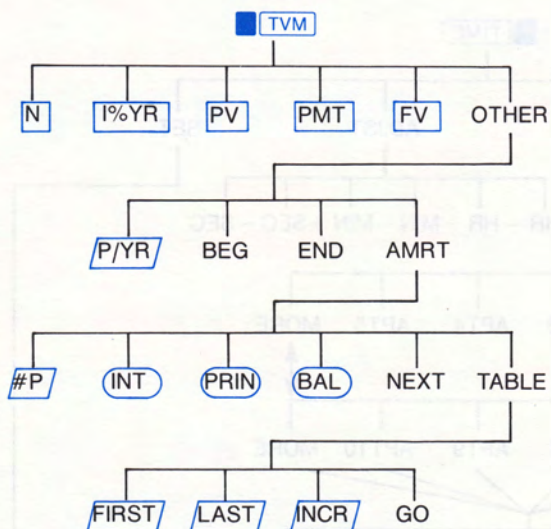

Time Menu Map

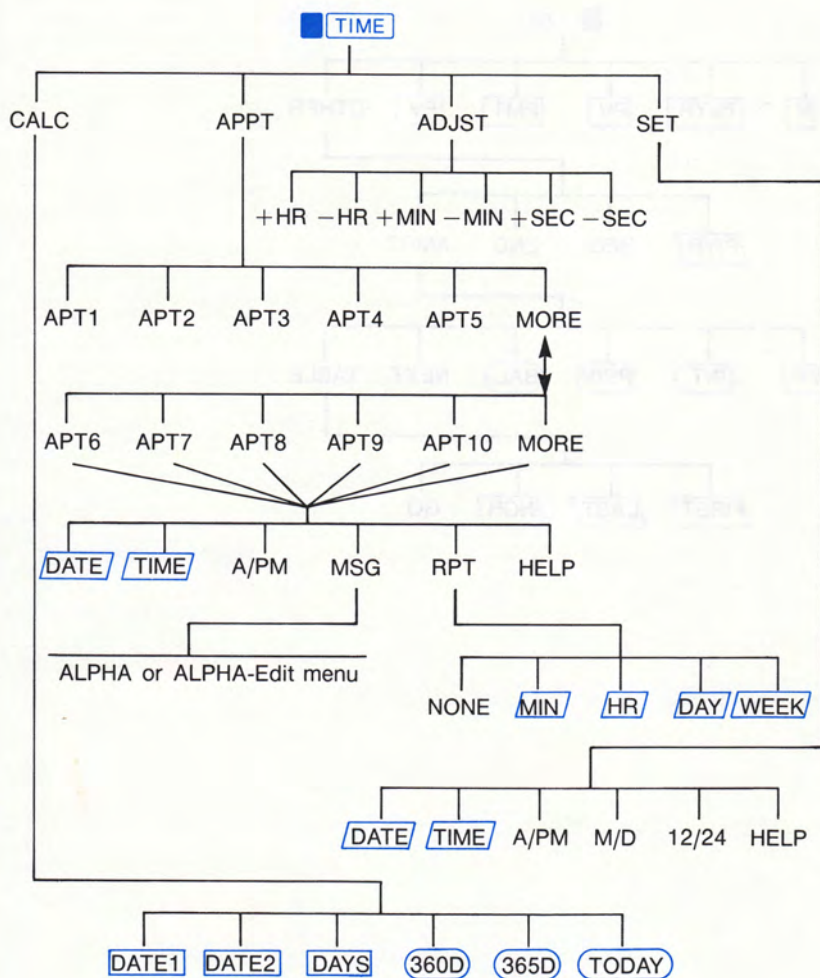

Numeric Function Menus

<input type="checkbox"/> BASE	DEC	HEX	OCT	BIN		
<input type="checkbox"/> PROB	X	Y	C X,Y	P X,Y	N!	RAN#
<input type="checkbox"/> HYP	SINH	COSH	TANH	ASNH	ACOSH	ATNH
<input type="checkbox"/> CONVERT	>DEG	>RAD	>HR	>HMS		MORE
	XCORD	YCORD	R	Δ	D/R	MORE
<input type="checkbox"/> %CHG	OLD	NEW	%CH			
<input type="checkbox"/> PARTS	IP	FP	RND	ABS		

Control Menus

<input type="checkbox"/> MODES	FIX	SCI	ENG	ALL	./,	MORE
	D/R	BEEP	PRNT			MORE
<input type="checkbox"/> PRINTER	LIST	STK	REGS	TIME	MSG	TRACE

Error Messages

The messages are listed in alphabetical order. The calculator distinguishes between math errors on the calculator line and other types of errors— messages for math errors start with **ERROR:**.

Press **[CLR]** or **[◀]** to erase error messages and restore the previous display.

BAD GUESSES:

PRESS [CLR] TO VIEW

The Solver cannot begin a numerical search using the initial estimates (see page 116).

BATT TOO LOW TO PRINT

The calculator requires fresh batteries before information can be printed.

**CURRENT LIST UNNAMED;
NAME OR CLEAR THE LIST**

Attempted to get another list without first clearing or naming the current list. Press **[CLEAR DATA]** to clear the list or **[NAME]** to name it.

EMPTY LIST

Attempted to do a calculation using an empty STAT list.

ERROR: LOGARITHM (NEG)

ERROR: LOGARITHM(0)

Attempted to take the base 10 or natural log of a negative number or zero. This can happen during curve-fitting calculations if you attempt to calculate:

- A logarithmic forecasting model with a negative or zero x -value.
- An exponential forecasting model with a negative or zero y -value.
- A power forecasting model with a negative or zero x - and/or y -value.

ERROR: NEG^NONINTEGER

Attempted to raise a negative number to a non-integer power.

ERROR: OVERFLOW

An internal result in a calculation was too large for the calculator to handle.

ERROR: SQRT(NEG)

Attempted to calculate:

- The square root of a negative number.
- The grouped standard deviation with a negative frequency.

ERROR: UNDERFLOW

An internal result in a calculation was too small for the calculator to handle.

ERROR: 0^NEG

Attempted to raise zero to a negative power.

ERROR: 0÷0

Attempted to divide zero by zero.

ERROR: 0^0

Attempted to raise zero to the zero power.

ERROR: ÷0

Attempted to divide by zero.

INPUTS CAUSED $\div 0$

The numbers stored in variables caused a division by zero in the calculation. Change one or more stored values.

INSUFFICIENT DATA

- Attempted to calculate standard deviation with only one value in the list.
- Attempt to do curve fitting using an x -variable list in which all the items are equal.
- Attempt to do curve fitting using the logarithmic or power models with a list for which the transformed values of x ($\ln(x)$) are equal.

INSUFFICIENT MEMORY

The calculator has insufficient memory available to do the operation (see "Managing Calculator Memory" on page 194).

INTEREST $\leq -100\%$

$I\%YR \div P/YR$ is less than or equal to -100 in the TVM application.

INTERRUPTED

Calculation of $I\%YR$ (in the TVM application), amortization results, a Solver variable, or a STAT list sort was interrupted.

INVALID DATE

The number entered cannot be interpreted as a proper date. Check its format (page 138). Acceptable dates are:

- Clock/calendar and appointments: 1/1/1987 – 12/31/2086.
- Date arithmetic: 10/15/1582 – 12/31/9999.

INVALID EQUATION

The Solver cannot interpret the equation due to a syntax error. Refer to "The Syntax of Equations" on page 96.

SOLUTION NOT FOUND

No solution was found for a Solver equation using the current values of the variables (see page 116 and page 226).

TOOBIG

The magnitude of the number is too large to be converted to HEX, OCT, or BIN base. The number must be in the range $-34,359,738,368 \leq n \leq 34,359,738,367$.

UNDERFLOW

Warning (displayed momentarily); the magnitude of a result is too small for the calculator to handle. The HP-27S returns 0. (See "Range of Numbers" on page 62.

UNEQUAL LIST LENGTHS

Attempted a two-list STAT calculation (curve-fitting, weighted mean, grouped standard deviation, summation statistics) using lists of unequal lengths.

Index

Page numbers in **bold** type indicate primary references; page numbers in regular type indicate secondary references.

Special Characters A

- >DEG** key, 55
- >HMS** key, 55
- >HR** key, 55
- *NEW** key, 75
- >RAD** key, 55
- #P** key, 131
- ΣX** key, 80
- ΣX^2** key, 80
- ΣXY** key, 80
- ΣY** key, 80
- ΣY^2** key, 80
- 12/24** key, 138, 139
- 360D** key, 145
- 365D** key, 145
- =** key, 18
- $1/x$** key, 51
- %** key, 51
- %CHG** key, 24
- π** key, 54
- +/-** key, 19
- \sqrt{x}** key, 51
- 10^x** key, 53
- %CH**, 28–29, 51
- %CHG** menu, 28–29, 51, 231
- Σ Solver function**, 101, 108–110, 181, 184, 186
- χ^2 statistics**, 183–185
- R/PM** key
 - for setting appointment time, 141
 - in SET menu, 138
- ABS** (absolute value) key, 61
- ABS Solver function**, 98
- AC adapter**, printing with, 149
- Accounts, savings**, 127–130
- Accuracy of clock**, 196
- Acknowledging appointments**, 142–143
- ACOS** key, 54–55
- ACOS Solver function**, 98, 171
- ACOSH** key, 60
- ACOSH Solver function**, 98
- Actual calendar**, 136, 145, 147
- Actuarial functions**,
 - equations for, 226
 - Solver functions, 102
- Adding vectors**, 154–156
- ADJST** key, 137
- Adjusting the clock**, 139
- Advance payments, leasing**, 172–176
- Alarms**, 140–147, *See also*
 - Appointments
- ALL display mode**, 31
- ALOG Solver function**, 98
- ALPHA-edit menu**, 38–39

- ALPHA** key, 39
- ALPHA menu, 35-40
- Alphabetic characters, typing, 36-38
- AM/PM, switching between, 137, 138
- American calendar format, 136
- Amortization
 - definition, 117
 - equations for, 232
 - menu, 119, 131
 - schedule, calculating, 131-133
 - schedule, printing, 131, 134-135
- AMRT** key, 119
- AMRT menu, 119, 131
- AND operator, 103-104
- Angle
 - between two vectors, 156-157
 - conversions, 55-56
 - degrees or radians, 53-54
- ANGLE Solver function, 98
- Annunciator
 - appointment, 142-143
 - definition, 20
 - low batteries, 15, 191
 - print, 20, 148
 - radians, 20, 54
 - shift, 20, 21
- Antilogarithms, 53
- Applications,
 - definition, 23
 - during ALPHA entry, 38
 - entering, 25
 - leaving, 25
 - switching, 26
 - top-level menu of, 23
 - using numeric functions with, 27
- Appointment(s)
 - acknowledging, 142-143
 - annunciator, 20, 142, 143
 - beeper, 35
 - clearing, 143
 - memory used by, 195
 - message, 140, 142
 - number, 140
 - past due, 140, 143
 - printing, 151
 - repeating, 141, 142
 - setting, 140-142
 - status of, 140
 - unacknowledged, 143
 - viewing, 140-141
- APPT** key, 137, 140
- APPT menu, 140-141
- Arc cosine, 54-55
- Arc sine, 54-55
- Arc tangent, 54-55
- Arithmetic
 - for dates, 145-147
 - in calculator line, 18-19, 42-46
 - in HEX, OCT, or BIN base, 63, 67-68
 - in registers, 47-48
 - operators, 42-44
- Arrangements (permutations), 59
- Arrow keys
 - changing the current equation, 91
 - moving through STAT lists, 72
 - rolling the history stack, 22
 - viewing long equations, 93
- ASIN** key, 54-55
- ASIN Solver function, 98
- ASINH Solver function, 98
- ASNH** key, 60
- ATAN** key, 54-55
- ATAN Solver function, 98
- ATNH** key, 60
- ATANH Solver function, 98
- Available memory, determining, 34, *See also* Memory
- Average, moving, 181-183

B

- B, equation for, 229
- B** key, 80–82
- Backspace, 21
- Bad guesses, 116, 222
- BAL** key, 131
- Balance of loan, 130, 131–132
- Balloon payment, 125–127
- Base 10 logarithm and antilogarithm, 53
- Base arithmetic, 63, 67–68
- Base conversions, 63–68
- BASE** key, 24
- BASE menu, 63–68
- Batteries
 - effect on printing, 191
 - installing, 191
 - life, 191
 - low, 191
- BEEP** key, 35
- Beeper, turning on and off, 35
- BEG** key, 119
- Begin mode, 119
- BIN** key, 63
- Bytes of memory remaining, 34

C

- CALC** key
 - in SOLVE menu, 91
 - in STAT menu, 76–77
 - in TIME menu, 137
- CALC menu,
 - in SOLVE, 92
 - in STAT, 77
 - in TIME, 145
- Calculate-only variables, 30

- Calculator line
 - arithmetic in, 18–19, 42–46
 - clearing, 21
 - containing more than 22 characters, 19
 - displaying in STAT menu, 70
 - for simple calculations, 18
 - editing, 21
 - memory requirements of, 195
 - printing, 149
 - using 16, 42
- Calculator technical support, 189
- Calendar
 - actual, 136, 145, 147
 - format, 136
 - setting, 138
 - specifying in Solver, 99
 - 360-day, 136, 145, 147
 - 365-day, 136, 145, 147
- Car loan, 123–124
- Carbon-14 dating, 40–41
- Case 1 solutions, 113–114, 211–215
- Case 2 solutions, 114–115, 215–222
- Case 3 situation, 116, 222–223
- Case 4 situation, 116, 224
- Cash flow
 - definition, 117
 - diagrams, 120–121
 - sign of, 120
- Catenary equation, 168–170
- CDATE Solver function, 98, 188
- Chain calculation
 - doing, 18–19, 43–45
 - operator priority during, 43–44
 - used in a menu calculation, 30
- Changing list numbers, 72
- Changing the sign of a number, 19
- Characters, alphabetic, typing, 36–38
- Checkbook, updating, 73–74
- Chi-squared statistics, 183–185

- CLEAR DATA** key
 - general information, 22
 - in AMRT menu, 132
 - in APPT menu, 143
 - in menus of variables, 93
 - in SOLVE menu, 95
 - in STAT menu, 76
 - in TIME CALC menu, 147
 - in TVM menus, 122
- Clearing
 - appointments, 143
 - calculator line, 21
 - date arithmetic variables, 147
 - list names, 76
 - Solver variables, 93
 - STAT lists, 76
 - TVM variables, 122
 - variables, 30, 93
- Clock
 - accuracy, 196
 - adjusting, 139
 - setting, 137
- CLR** key
 - to clear calculator line, 21, 39
 - to see Solver estimates, 111
 - to turn on calculator, 15
- Combinations
 - calculating, 59, 163–164
 - equation for, 231
 - Solver function for, 98
- COMB Solver function, 98
- Comma, interchanging with period, 34
- Compound interest
 - calculations, 117–135
 - definition, 117
- Compounding periods, 120
- Conditional expressions, 103–105
- Conditional operators
 - description of, 103–104
 - priority of, 97
- Constants, in Solver, 96
- Continuous compounding, 177
- Continuous Memory, *See also*
 - Memory
 - definition, 15
 - erasing, 196
- Contrast of display, 15
- Control menus
 - definition, 28
 - table of, 237
- Conversions, angles and hours, 55–56
 - CONVERT** key, 24 *See also* CONVERT menu
- CONVERT menu
 - decimal degrees/D.MMSS, 55–56
 - degrees/radians, 55–56
 - equations for, 231
 - examples, 154–159
 - polar/rectangular coordinates, 57
 - using, 55–58
- Converting between number bases, 63–64
- Coordinate conversions
 - calculations, 57–58
 - equations for, 231
- Copying list number to calculator line, 74
- CORR, *See* Correlation coefficient
- CORR** key, 80–82
- Correlation coefficient
 - calculating, 80
 - equation for, 229
- COS** key, 54–55
- COS Solver function, 98
- COSH** key, 60
- COSH Solver function, 98, 168
- Cosine, hyperbolic, 60
- Cosines, law of, 160, 162
- Counter variable, in Σ function, 108
- Creating lists, 75
- CTIME Solver function, 99
- Cube root, 51
- Current date
 - in date arithmetic, 145
 - viewing, 136

Current equation
definition, 91
deleting, 95
editing, 93
printing, 149
Current list, 70
Current time, viewing, 136
Curve fitting
calculations, 81–85
equations for, 229
list contents for 79
C X,Y, equation for, 231

D

D/R key, 54
Date
arithmetic, 145–147
format for keying in, 138
in the past or future, 147
setting, 138
viewing, 136
Date format, changing, 139
DATE key, 138
DATE Solver function, 99
DATE1 key, 145
DATE2 key, 145
Day.month.year format, 136, 138
Day of the week, determining, 145
DAYS key, 145
Days between two dates, 146
DDAYS Solver function, 188
DEC key, 63
Decimal hours, 55–56
Decimal places, 31–32
Decimal point, interchanging with
comma, 34
Default settings, 196
DEG Solver function, 99
Degrees mode, 53–54
Degrees to radians, 55–56
DEL key, 39
DELET key
in SOLVE, 91
in STAT menu, 70, 72

Deleting
equations, 95
list numbers, 70, 72
variables, 94–95
Diagnostic messages, 20
Diagnostic self-test, 198–199
Dice, simulating, 165
Digit separator, changing, 34
Digits, showing all of, 34
Direct solutions
definition of, 110, 204–206
more than one answer, 206
requirements for, 204–205
Discontinuous function, 214–215
Display
clearing, 22
configurations, 16
contrast, 15
format, 30–34
messages, 20. *See also* Messages
mode, 30–34
width, exceeding, 19
Distance between locations, 171–172
Division, in HEX, OCT, or BIN base,
67

E

E key, 33
EDIT key, in SOLVE menu, 91,
93
Editing
alphabetic characters, 38–40
calculator line, 21
equation, 93
list name, 74–75
STAT list, 72
Effective interest rate, 176
END key, 119
End mode, 119
ENG key, 33
Engineering notation, 33–34
Entering data into STAT list, 71–72
Entering equations, 91–92
Environmental limits, 197

Equations

- deleting, 94-95
 - editing, 38-40, 93
 - entering, 91-92
 - functions, 96, 98-109
 - length, 96
 - memory requirements of, 195
 - naming, 94
 - printing, 149, 151
 - syntax rules of, 96-97
 - typing, 36-38
 - variables, printing, 151
 - viewing, 91, 93
- Error messages, 20, 21, 35, 238-240
- Estimates, entering in Solver, 92
- Estimation calculations, 79, 80-82
- European calendar format, 136
- EXIT** key, 17, 25
- EXP Solver function, 99
- EXPM1 Solver function, 99
- Exponential model, 81-82
- Exponential notation, 32-34
- Exponentiation, 19
- Exponents, changing the sign of, 33
- e^x** key, 53

F

- Factorial, 60
- FACT Solver function, 99
- FIX format, 31-32
- Format
- date, 138
 - of numbers, 30-34
 - time, 137
- Formulas, *See* Equations
- FP** key, 61
- FP Solver function, 99, 188
- Fractional part, 61
- FRCST** key, 77
- Free-fall equation, 89
- Frequencies, for grouped standard deviation, 79, 85
- Full precision, showing, 34

Functions

- in Solver, 96, 98-109
 - numeric, 49-62
 - roots of, 179-180
- Future date, determining, 147
- Future value
- of a single payment, 101, 226
 - of a series of payments, 102, 227
 - variable in TVM, 119
- FV** key, 119

G

- GET** key, 70, 75-76
- Grouped standard deviation
- calculating, 85
 - equation for, 228
 - list contents for, 79
- G.SD** key, 80
- Guesses
- bad, 222
 - entering, 92, 112-113
 - used to find roots, 179-180, 209, 212-213

H

- Halting an iterative solution, 111
- HELP** key, 138, 141
- Help messages, 20
- HEX** key, 63
- HEX menu, 63
- Hierarchy of operators
- in calculator line, 43-44
 - in Solver, 96-97
- History stack, 17
- clearing, 22
 - definition of, 17
 - previous result in, 46
 - printing, 150
 - viewing, 22
- HMS Solver function, 99
- Hours-minutes-seconds, 55-56
- HRS Solver function, 99, 171

Humidity limits, 197

HYP key, 24

Hyperbolic functions, 60

I

IDIV Solver function, 99

IF function

description of, 100, 103-105

example using, 188

nesting, 105

Individual Retirement Account,
129-130

Infrared printer, 148

INPUT key

in arithmetic calculations, 21

with STAT lists, 71-72

Inserting characters, 39

Inserting numbers, 72

INSR key, 70, 72

Installing batteries, 192-193

Insufficient memory, 35, 194

INT key, 131

INT Solver function, 100

Integer part, 61

Interest

payments applied towards, 130,
131-132

rate conversions, 176-178

TVM variable, 119

Internal representation of numbers,
31

Interrupting the Solver, 111

INV Solver function, 100

Invalid equation, 92

Inverse hyperbolic functions, 60

IP key, 61

IP function, 165

IP Solver function, 100

IRA, 129-130

ITEM prompts, 70

ITEM Solver function

description of, 100, 110

examples using, 181, 184, 186

Iterative solution

case 1, 211-215

case 2, 215-222

case 3, 222-223

case 4, 116, 224

definition of, 207

forcing, 206

halting, 111

interpreting, 113-116

method for finding, 207-209

outcomes of, 113-116

requirements for finding a root,
209

restarting, 111

round-off error, 224

solution not found, 224

I \times YR key, 119

K

Keyboard functions, 42-62

Known variables, 28

L

Labels on display, 16-17

Largest number in a STAT list, 77

LAST key, 46

Law of cosines, 160, 162

Law of sines, 160-161

Leap years, 145

Lease

calculating the payment, 172-174

cash flow diagram for, 121

present value of, 174-176

LEFT, 111-115

Letter menus, 36-37

Letters, typing and editing, 35-40

Linear model, 81-82

Linear regression, 81-85

LIST key, 150-151

Lists

- inserting and deleting numbers, 70, 72
- moving through, 72
- naming, 74-75
- printing, 151

LN Solver function, 100

LN key, 53

LNP1 Solver function, 100

Loans

- amortizing, 130-135
- calculations for, 123-127
- cash flow diagrams for, 120

LOG Solver function, 100

LOG key, 53

Logarithmic functions, 53

Logarithmic model, 81-82

Logical operators, 103-104

Low battery annunciator, 15, 20, 148, 191

Low memory, 35, 194

M

M key, 80-82

M/D key, 138, 139

Machine reset, 191, 195

MAIN display, 16

MAIN key, 17, 23, 25

Mantissa, 32, 33

Math functions, 18

MAX key, 77

MAX Solver function, 100, 188

Mean

calculating, 77

equation for, 228

MEAN key, 77

Mean for grouped data, 85, *See also* Weighted mean

Median

calculating, 77

equation for, 228

MEDN key, 77

MEM key, 34

Memory

determining available, 34-35

erasing, 196

insufficient, 194

managing, 194-195

requirements, 195

Memory lost message, 196

Menu keys 16-17, 22, 43

Menu map

for SOLVE, 233

for STAT, 234

for TIME, 236

for TVM, 235

Menu of variables, 29, 40, 92

Menus

application, 23, 24, 25-26

control, 23, 24, 237

for more than one equation, 106-107

numeric function, 23, 24, 237

of variables, clearing, 30

table of, 24

using, 22-30

Messages

for appointments, 140, 142

clearing, 20

diagnostic, 20

error, 20, 238-242

help, 20

memory requirements of, 195

printing, 151

MIN key, 77

MIN Solver function, 100, 181

Minimum of a function, 220-222

MOD Solver function, 100

Models, for curve fitting, 81-82, 229

Modes

display, 30-34

print-speed, 149

set by menus, 23, 24

start-up, 196

trace printing, 152

MODES key, 24
MODES menu, 16, 30-34, 54
MODL key, 80
Month/day/year format, 136, 138
Mortgage
 amortization schedule for, 132-135
 calculations, 124-127
Motion of a projectile, 166-168
Moving average, 181-183
MSG key, 150, 151
Multiplication, specifying in Solver,
 97

N

N key, 119
NI key, 60
N, non-integer, 129
NAME key, in STAT menu, 70
Naming
 equations, 94
 STAT lists, 74-75
Natural logarithm and antilogarithm,
 53
Nautical miles, 171
Negative numbers
 decimal, 19
 exponents, 33
 in HEX, OCT, BIN base, 65
neighbors, estimates in Solver, 113
NEW, 28-29, 51
NEW key
 in %CHG menu, 28-29, 51
 in SOLVE menu, 91
New lists, creating, 75
NEXT key, 131
Nominal interest rate, 176
Non-integer N, 129
NOT operator, 103-104
Notes, printing, 151
Number bases, switching, 63-64
Number lists, 69
Number of payments, in TVM, 119
Number of payments per year,
 changing, 122

Numeric function menus, 27, 237
Numeric functions, 23, 24, 42-62

O

OCT key, 63
OLD, 28-29, 51
OLD key, 28-29, 51
One-variable statistics, 76-79
Operator keys, 18
Operator priority
 in calculator line, 43-44
 in Solver, 96-97
OR operator, 103-104
OTHER key, 118-119
Overflow
 in arithmetic calculations, 62
 in HEX, OCT, BIN base, 68

P

Parentheses
 in calculator line, 45
 in Solver, 97
PARTS key, 24
PARTS menu, 61
Past date, calculating, 147
Past due appointments, 140, 143
Payment conditions, clearing, 122
Payment mode, setting, 119, 122
Payment periods, 119, 120
Payments
 lease, 172-174
 total number of, in TVM, 119
Pending appointments, 140
Percent, 51
Percent change
 calculations, 28-29, 52
 equation for, 231
 menu, 22
Period, interchanging with comma,
 34
Periodic compounding, 177
PERM Solver function, 100

- Permutations
 - calculations, 59
 - equation for, 231
 - example using, 164–165
 - PI (**π**), 54
 - PI Solver function, 100
 - PMT** key, 119
 - Polar coordinates
 - adding vectors in, 154–156
 - calculations, 57–58
 - examples using, 156–157, 159
 - Pole, 217
 - Population standard deviation, 77
 - Power, battery, 191–193
 - Power model, 81–82
 - Power on and off, 15
 - Precision, full, displaying, 32
 - Precision of numbers, internal, 31
 - Present value
 - definition, 119
 - of a lease, 174–174
 - Previous menu, displaying, 25
 - Previous result, using, 16–17, 46
 - PRIN** key, 131
 - Principal, payments applied towards, 130, 131–132
 - Print annunciator, 20, 148
 - Print-speed mode, 149
 - Print tracing, 152
 - PRINTER menu, 150–152
 - PRINTER** key, 24, 150
 - Printing
 - amortization schedule, 134–135
 - calculator line, 149
 - descriptive messages, 151
 - equations, 149
 - STAT lists, 151
 - variables, 151
 - Priority of operators
 - in calculator line, 43–44
 - in Solver, 96–97
 - PRNT** key, 149
 - PROB** key, 24
 - PROB menu, 59–60
 - Probability
 - equations for, 231
 - example using, 163–165
 - menu, 59–60
 - Projectile motion, 166–168
 - Projection of a vector, 158–159
 - PRT** key, 149
 - Punctuation characters, 36–37
 - PV** key, 119
 - P X,Y*, equation for, 231
 - P/YR** key, 119
- ## R
- RAD annunciator, 20, 54
 - RAD Solver function, 100
 - Radians mode, 53–54
 - Radians to degrees, 55–56
 - Radio frequency interference, 203
 - Radioactive decay, 36,37–38, 40
 - RADIUS Solver function, 100
 - Radix, changing, 34
 - Raising a number to a power, 19
 - RAN# Solver function, 100, 165
 - Random number
 - generating, 60
 - seed at start-up, 196
 - Solver function, 100, 165
 - RANG** key, 77
 - RANGE
 - calculating, 77
 - equation for, 228
 - Range of numbers
 - decimal numbers, 62
 - in HEX, OCT, BIN base, 65–66
 - RCL** key, 30, 46
 - Reciprocal of a number, 51
 - Rectangular coordinates
 - calculating, 57–58
 - examples using, 154–159

Registers
 arithmetic in, 47-48
 clearing, 47
 using, 46-47
 REGS key, 150
Relational operators, 103
Relative minimum, 220-221
Remaining memory, determining, 34
Renaming a list, 74-75
Repeating appointments, 141, 142
Replacing batteries, 192-193
Representation of numbers, 65
Resetting the calculator, 195
Restarting an iterative solution, 111
Result, using in another calculation,
 46
RIGHT, 111-115
 RND key, 61
RND Solver function, 101
Root of a number, 51
Roots of a function
 calculating, 207-225, *See also* Iterative solutions
 definition of, 207-219
 finding, 179-180
 more than one, 179-180, 211,
 212-213
Round-off error, 26
Rounding a number, 61
Running balance, 73-74
Running total, in STAT list, 71

S

S Solver function, 101, 106-107, 166
Sample standard deviation, 77
Santa Claus, 188
Savings accounts, 127-130
 SCI key, 33
Scientific notation, 32-34
Scrolling characters, 19
Seed, for random number, 60

Self-test, 198-199
Series expansion, 109
Service
 charge for, 201-202
 determining if necessary, 197-198
 obtaining, 201
 shipping calculator for, 202
 warranty on, 202
 SET key, 137
SET menu, 138
Setting
 appointment, 140-142
 date, 138
 time, 137
SGN Solver function, 101
Shared variables, in Solver, 94
Shift annunciator, 20, 21
Shift key, 21
 SHOW key, 34
Sigma (Σ) Solver function, 101,
 108-110, 181, 184, 186
Sign of number, changing, 19
Sign conventions in TVM, 120
 SIN key, 54-55
SIN Solver function, 101
Sine, hyperbolic, 60
Sines, law of, 160-161
SINH function, 168
 SINH key, 60
SINH Solver function, 101
 SIZE key, 80
Size of STAT list, 80
SIZES Solver function, 101, 110, 184
Slope of a line, calculating, 80
Solution not found
 in direct solutions, 205
 in iterative solutions, 207, 224
Solutions
 direct, 204-206, *See also* Direct solutions
 iterative, 207-225, *See also* Iterative solutions
 SOLVE key, 24

- Solver
 calculations, 92
 direct solutions, 204–206, *See also*
 Direct solutions
 entering, 90–91
 equations, printing, 40, 149, 151
 functions, 98–109
 introduction to, 35–40
 iterative solutions, 207–225, *See also* Iterative solutions
 menu map, 233
 round-off error in, 224
 solutions, 113–116
 variables, clearing, 93
 variables, printing, 151
 variables, retained in memory, 94
- Solving for function, 101, 106–107
√ key, 77
- Spaces, in equations, 97
- SPFV
 equation for, 226
 Solver function, 101
- Sphere, surface area, 54
- SPPV
 equation for, 226
 Solver function, 101
- SQ Solver function, 102
- SQRT Solver function, 102
- Square of a number, 51
- Square root, 51
- Standard deviation
 calculating, 77
 equation for, 228
 for grouped data, calculating, 79, 85
 for grouped data, equation for, 228
- Start-up settings, 196
- STAT application, 25–26, 69–88, 234
- STAT list
 entering data into, 71–72
 memory requirements, 195
 printing, 151
 subtotals of, 186–187
 viewing and editing, 72
- STAT menu, 70
STAT key, 24, 70
- Statistics
 application, 69–88
 equations for, 228–229
 one-variable, 76–79
 two-variable, 79–84
- Status annunciators, 20
- Status of appointments, 140
- Statute miles, 171
- STDEV, *See* Standard deviation
STDEV key, 77
STK key, 150
STO key, 29, 46, 51
- Storage registers, 46–48, *See also*
 Registers
- Store-only variables, 30
- Subtotals, 186–187
- Summation statistics
 calculating, 87
 list contents for, 79
- Summing function
 description, 101, 108–110
 examples using, 181, 184, 186
 with STAT lists, 110
- Support department, 189
- Surface area of a sphere, 54
- Switching equations, 91
- Switching lists, 75–76
- Syntax errors, 92
- T**
- TABLE** key, 131
TAN key, 54–55
 TAN Solver function, 102
 Tangent, hyperbolic, 60
TANH key, 60
 TANH Solver function, 102
 Technical support department, 189
 Temperature conversions, 94
 Temperature limits, 197
 Testing the calculator, 198–199

Time

- adjusting, 139
 - format for keying in, 137
 - setting, 137
 - viewing, 136
- TIME application, 136-147, 236
- Time format, changing, 139
- TIME** key, 24
- TIME** key
- in appointment menus, 141
 - in PRINTER menu, 150
 - in SET menu, 138
- TIME menu, 23, 136-137
- Time value of money, *See also* TVM calculations, 117-135
- equations for, 230
- TODAY** key, 145
- Top-level menu, 23, 26
- Toss of dice, simulating, 165
- TOTAL**
- calculating, 70, 77
 - equation for, 228
- TOTAL** key, 70, 77
- TRACE** key, 150, 152
- Trace printing, 152
- Trajectory, equation for, 166-168
- Triangles, 160-162
- Trigonometric functions, 53-55
- TRN Solver function, 102
- TVM
- application, entering, 118
 - calculations, 122
 - equations for, 230
 - menu map, 235
 - menu, second-level, 118, 119
 - menu, top-level, 118-119
 - payment conditions, 118, 119
 - variables, 118
 - variables, clearing, 122
- TVM** key, 25, 118
- Twelve hour clock, 136, 137
- Twenty-four hour clock, 136, 137
- Two-variable statistics, 79-84
- Two's Complement arithmetic, 67
- Typing aids, 38

U

- Unacknowledged appointments, 143
- Underflow, in arithmetic calculations, 62
- Unit conversions, using the Solver, 107
- Unknown variables, 28
- Unused memory, determining, 34
- USFV function
 - equation for, 227
 - Solver function, 102
- USPV
 - equation for, 227
 - Solver function, 102

V

- Variables
- calculating values for, 30
 - clearing, 30
 - definition, 28
 - deleting, 94-95
 - for date arithmetic, clearing, 147
 - memory requirements of, 195
 - printing, 151
 - recalling, 30
 - names, in Solver, 96
 - rules for using, 29-30
 - shared in Solver, 94
 - storing values for, 29
- Vectors
- adding, 154-156
 - angle between, 156-157
 - projections, 158-159
- Verification of equations, 92

W

- Warranty, 199-200
- Warranty on service, 202
- Weighted mean,
 - calculating, 85
 - equation for, 228
 - list contents for, 79
- W.MN, *See* Weighted mean
- W.MN** key, 80

X

- x^2 key, 18, 51
- X variable, in PROB menu, 59
- x-variable, in curve fitting, 80-82
- XCOORD Solver function, 102
- XCOORD variable, in CONVERT menu, 57
- XOR operator, 103-104

Y

- Y variable, in PROB menu, 59
- y-variable, in curve fitting, 80-82
- Y-intercept of a line, calculating, 80
- YCOORD Solver function, 102
- YCOORD variable, in CONVERT menu, 57
- y^x key, 19

Contacting Hewlett-Packard

For Information About Using the Calculator. If you have questions about how to use the calculator, first check the Table of Contents, the Subject Index, and "Answers to Common Questions" in appendix A. If you can't find an answer in the manual, you can contact the Calculator Technical Support department:

Hewlett-Packard
Calculator Technical Support
1000 N.E. Circle Blvd.
Corvallis, OR 97330, U.S.A.
(503) 757-2004
8:00 a.m. to 3:00 p.m. Pacific time
Monday through Friday

For Service. If your calculator doesn't seem to work properly, see appendix A to determine if the calculator requires service. Appendix A also contains important information about obtaining service. If your calculator does require service, mail it to the Calculator Service Center:

Hewlett-Packard
Calculator Service Center
1030 N.E. Circle Blvd.
Corvallis, OR 97330, U.S.A.
(503) 757-2002

For Information About Hewlett-Packard Dealers, Products, and Prices. Call the following toll-free number:

(800) 752-0900

Contents

Page	11	List of Examples
	14	How to Use This Manual
	15	1: Getting Started
	42	2: Keyboard Arithmetic and Numeric Functions
	63	3: Base Conversions and Base Arithmetic
	69	4: Statistics
	89	5: The Equation Solver
	117	6: Time Value of Money
	136	7: Time, Appointments, and Date Arithmetic
	148	8: Printing
	154	9: Additional Examples
	189	A: Assistance, Batteries, Memory, and Service
	206	B: More About The Solver
	228	C: Equations Used by HP-27S Menus
	234	D: Menu Maps and Tables
	240	Error Messages
	245	Index



**HEWLETT
PACKARD**

**Reorder Number
00027-90028**

00027-90046 English
Printed in U.S.A. 2/88